

8964015COM Storage Cabinet

systembuild[®]
EVOLUTION

Date of Purchase ___ / ___ / ___
Lot Number:

B348964015COM0

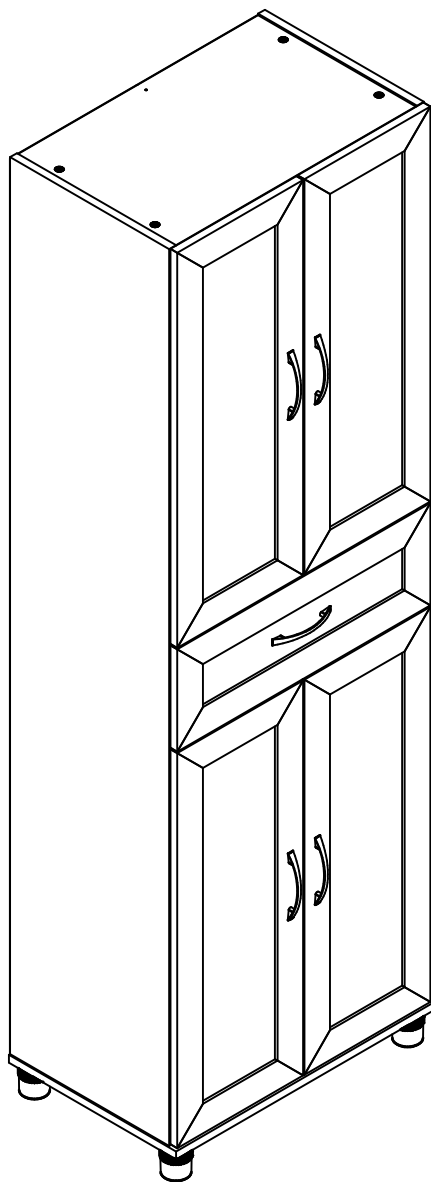

Do Not Return This Product!
Contact our customer service team for help first.
Call: 1-866-452-4081 (toll free)
Monday-Friday 9am - 5pm CST
Visit: www.systembuild.com

THIS INSTRUCTION BOOKLET CONTAINS **IMPORTANT** SAFETY INFORMATION. PLEASE READ AND KEEP FOR FUTURE REFERENCE.

Secure Your Furniture

Keep your home and family safe with the wall anchor kit that is included with the product.

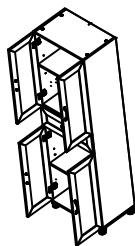

Serious or fatal crushing injuries can occur from tipping furniture.

WARNING: Manufacturer assumes no liability for improper installation or excessive loads placed on screws or bracket. This wall anchor is not a substitute for proper adult supervision.

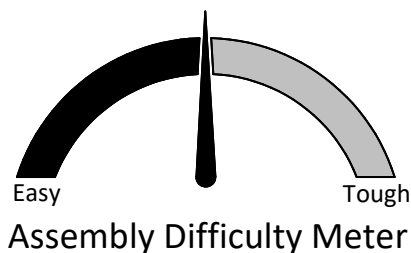

For the latest information on SystemBuild products
follow us at Ameriwood Home



Contact Us!

Do NOT return this product!

Contact our friendly customer service team first for help.

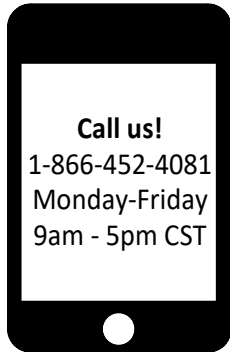

Visit systembuild.com to view the limited warranty valid in the U.S. and Canada.

Assembly Tips



Helpful Hints

PEOPLE NEEDED FOR ASSEMBLY: **1-2**
ESTIMATED ASSEMBLY TIME: **1 HOUR**

- Open your item in the area you plan to keep it to avoid excessive heavy lifting.
- Identify, sort and count the parts before attempting assembly.
- Compression dowels are lightly tapped in with a hammer.
- Slides are labeled with a **R** (right) and **L** (left) for proper placement.
- Make sure to always face the point on the top of the Cam Lock towards the outer edge.
- Use all the nails provided for the back panel and spread them out equally.
- Back panel must be used to make sure your unit is sturdy.
- Do NOT use harsh chemicals or abrasive cleaners on this item.
- Never push, pull, or drag your furniture.



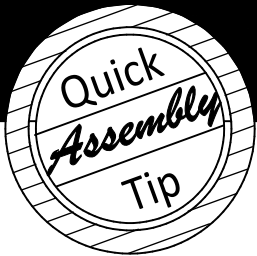

Before You Start

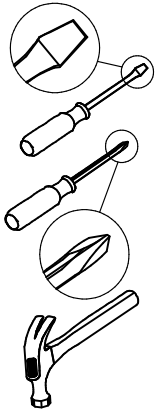

- ✓ Read through each step carefully and follow the proper order
- ✓ Separate and count all your parts and hardware
- ✓ Give yourself enough room for the assembly process
- ✓ Have the following tools: Flat Head Screwdriver, #2 Phillips Head Screwdriver and Hammer
- ✓ Caution: If using a power drill or power screwdriver for screwing, please be aware to slow down and stop when screw is tight. Failure to do so may result in stripping the screw.

Cam Lock Fastening System

This Cam Lock Fastening System will be used throughout the assembly process.

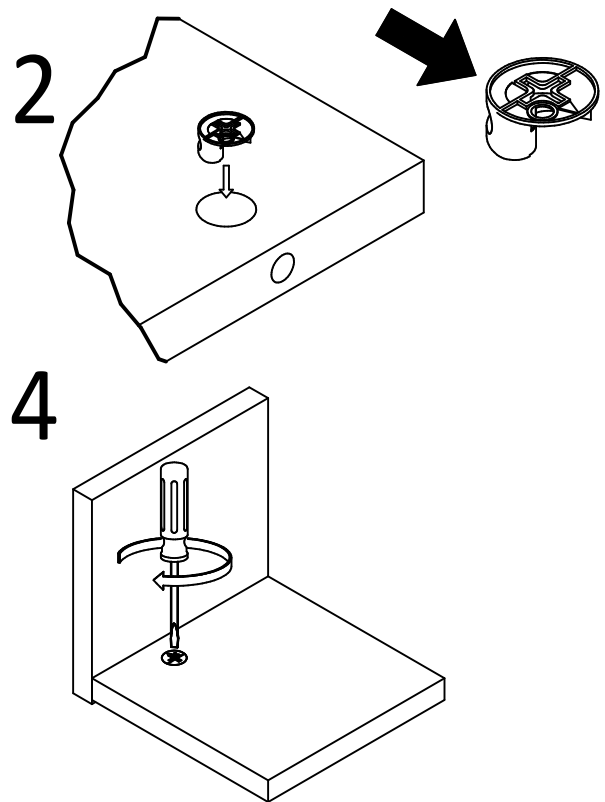
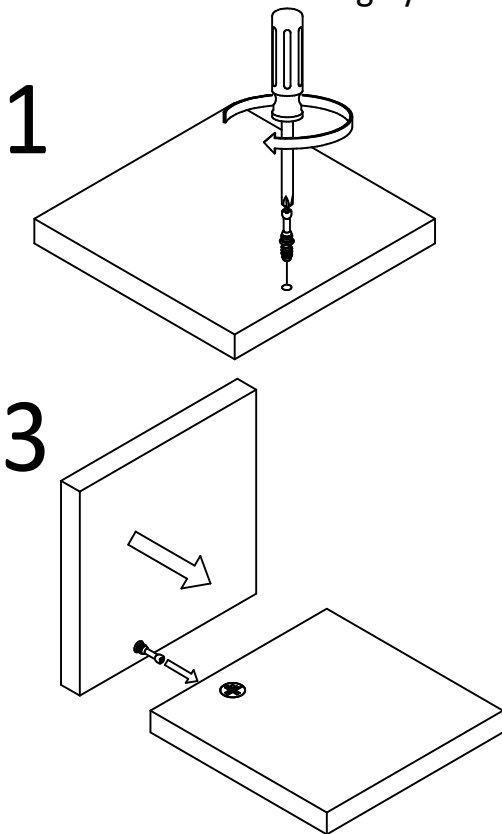

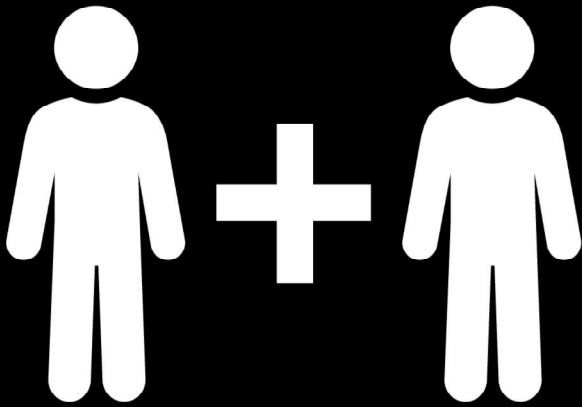

2 PEOPLE NEEDED FOR ASSEMBLY

**2 PERSONAS NECESITADAS
PARA LA ASAMBLEA**

**2 PERSONNES NÉCESSAIRES
POUR L'ASSEMBLAGE**

CAUTION: Failure to use 2 people for assembly could result in unit damage or personal injury.

PRECAUCIÓN: Si no se utilizan 2 personas para el ensamblaje, se pueden producir daños en la unidad o lesiones personales.

ATTENTION: Échec d'utiliser 2 personnes pour l'assemblage peut causer du dommage au meuble ou causer des blessures.

Board Identification

Not actual size

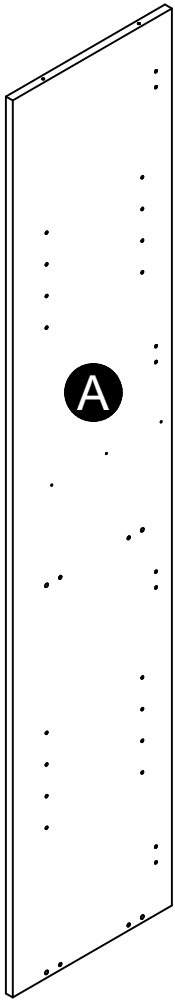

Left Panel
31117015010

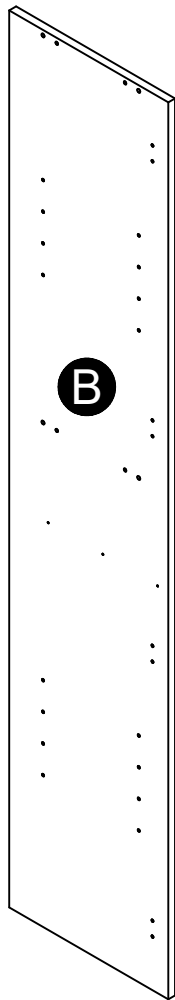

Right Panel
31117015020

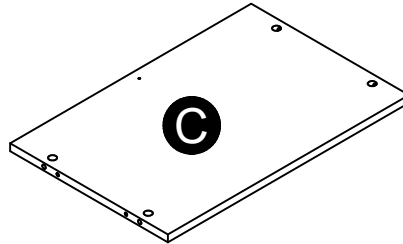

shelf (2)
31117015030

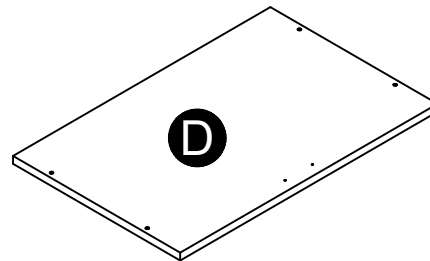

Bottom
31117015040

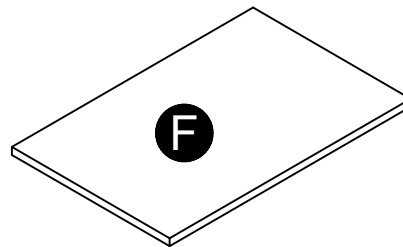

Adjustable shelf (2)
37362015060

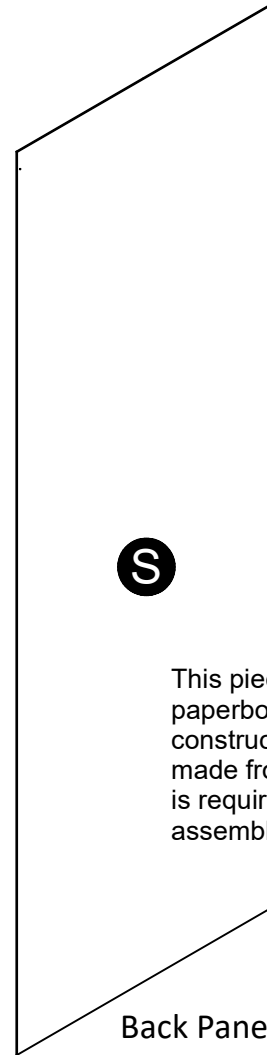

Back Panel
K111701500

This piece is paperboard construction. It is not made from wood, but is required for the assembly of your unit.

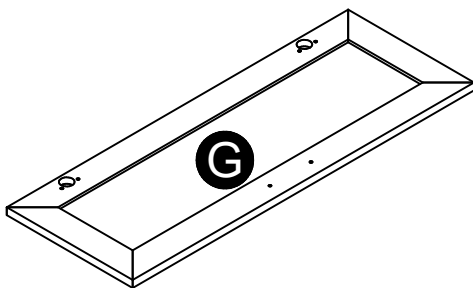

Door (4)
38964015070

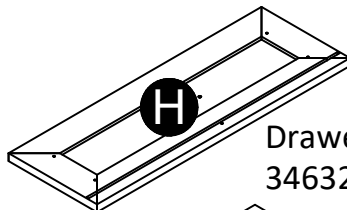

Drawer Front
34632015080

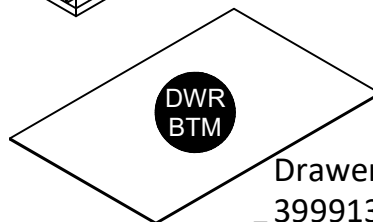

Drawer Bottom
39991341052210D

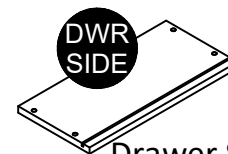

Drawer Side (2)
39991167346200C

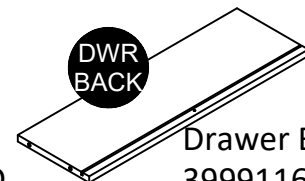

Drawer Back
39991167051390B

Board Identification

Not actual size

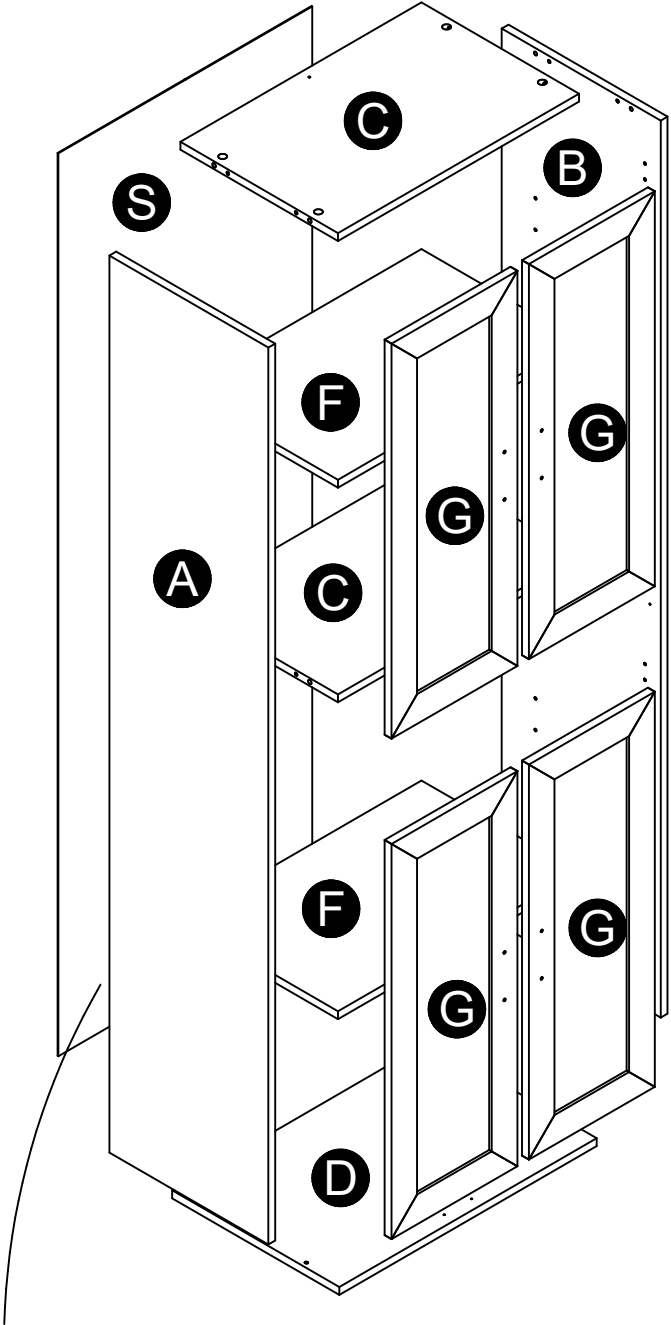

This piece is paperboard construction. It is not made from wood, but is required for the assembly of your unit.

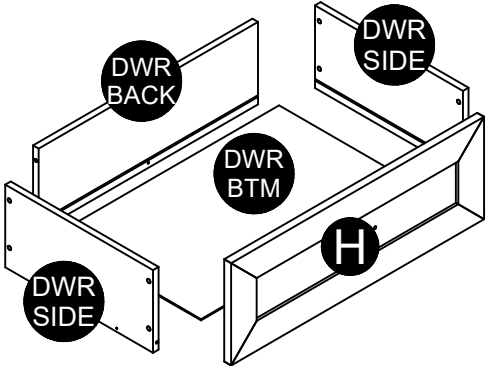

Part List

Actual Size

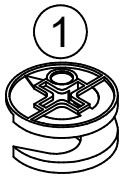

(x8)
#A22620
cam lock

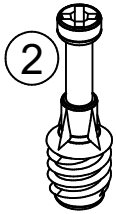

(x8)
#A22610
cam bolt

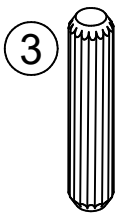

(x8)
#A21660
wood dowel

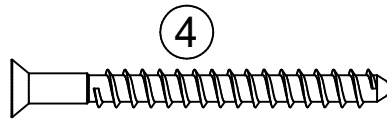

(x4)
#A23030
confirmat screw



(x8)
#A80250
shelf support

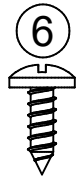

(x10)
#A12120
7/16" round
head screw



(x10)
#A11080
7/16" flat
head screw

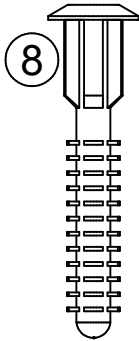

(x4)
#A21970
drive fastener



(x2)
#A11160
5/8" flat
head screw



(x8)
#A17400
8-32 x 7/8"

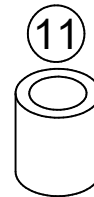

(x2)
#A89020
bumper



(x42)
#A21110
nail



(x4)
#A12930
1-1/8" round
head screw



(x8)
#A12420
5/8" round
head screw

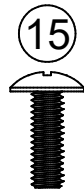

(x2)
#A17200
8-32 x 1/2"

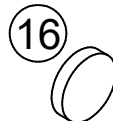

(x2)
#A89210
bumper

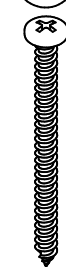
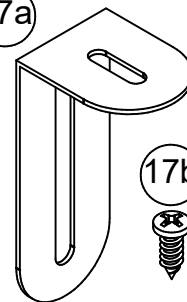

(x1)
#A84050
safety bracket kit

Part List

Not Actual Size

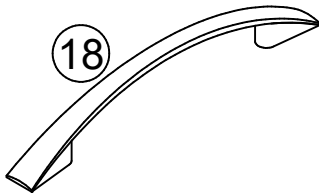

18

(x5)
#A52395
handle

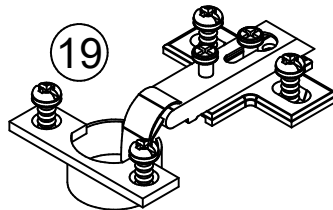

19

(x8)
#A65615
hinge

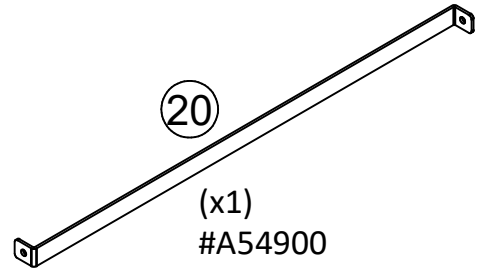

20

(x1)
#A54900
drawer brace

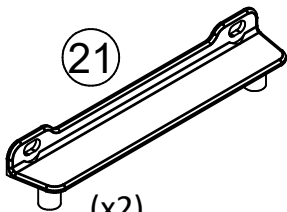

21

(x2)
#A54520
drawer bracket



23a

left cabinet member



23b

right cabinet member

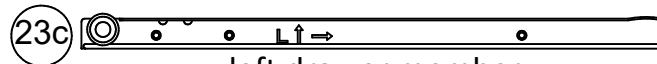

23c

left drawer member

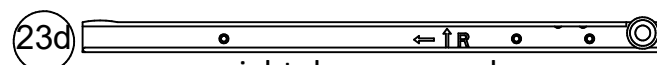

23d

right drawer member

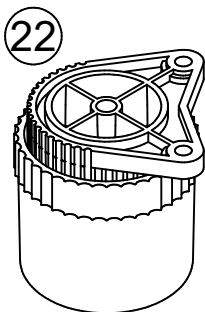

22

(x4)
#A44140
foot

(x1)
23 #A56770
drawer slide kit

STEP 1

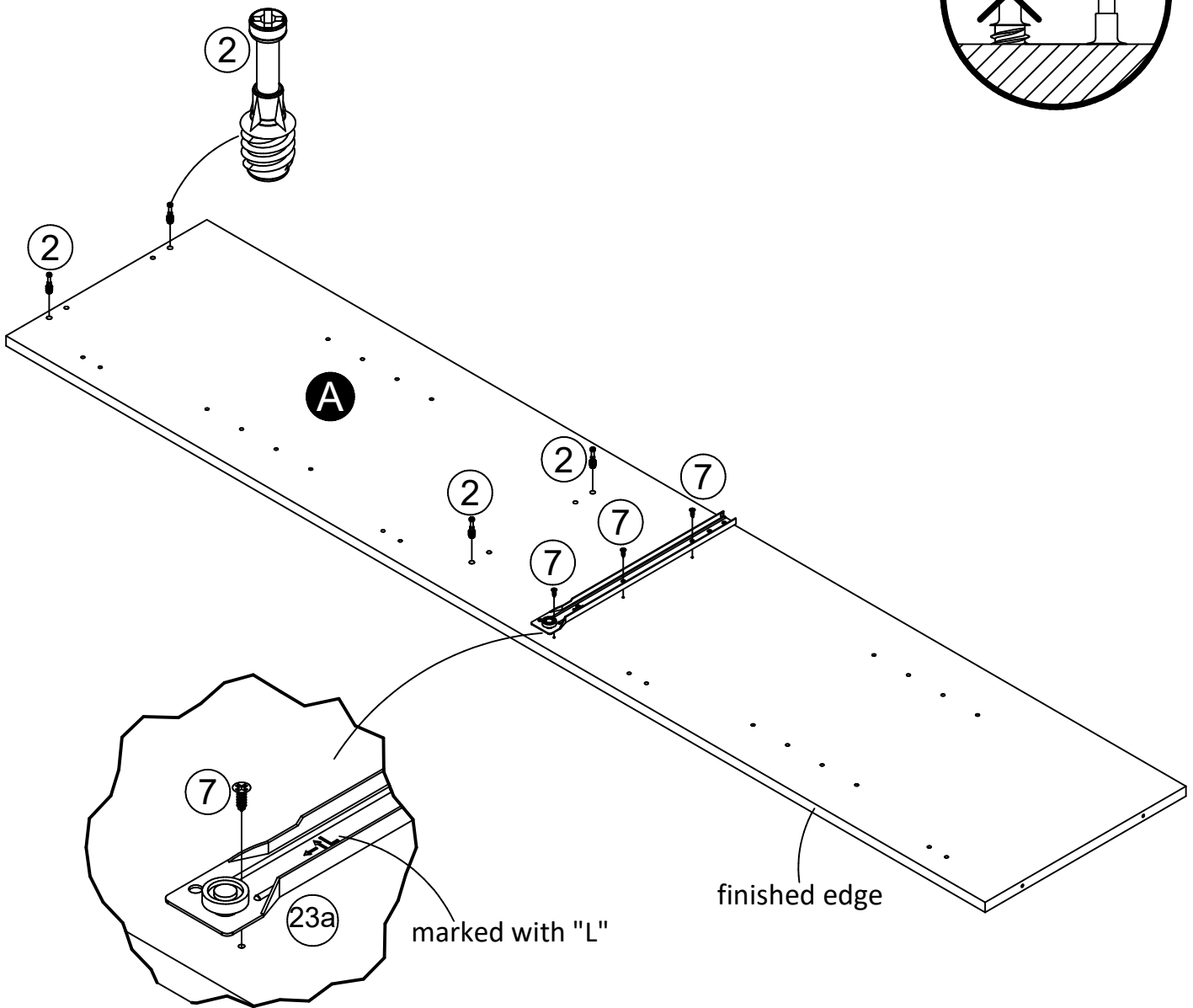
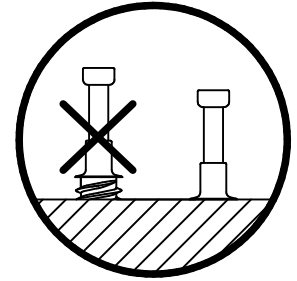
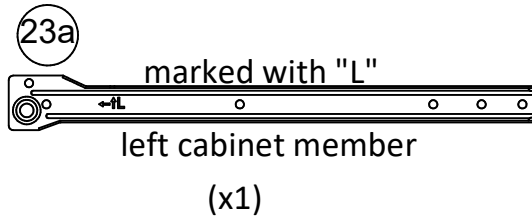
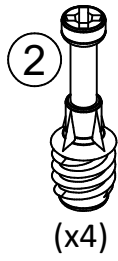
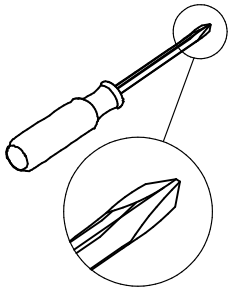

STEP 2

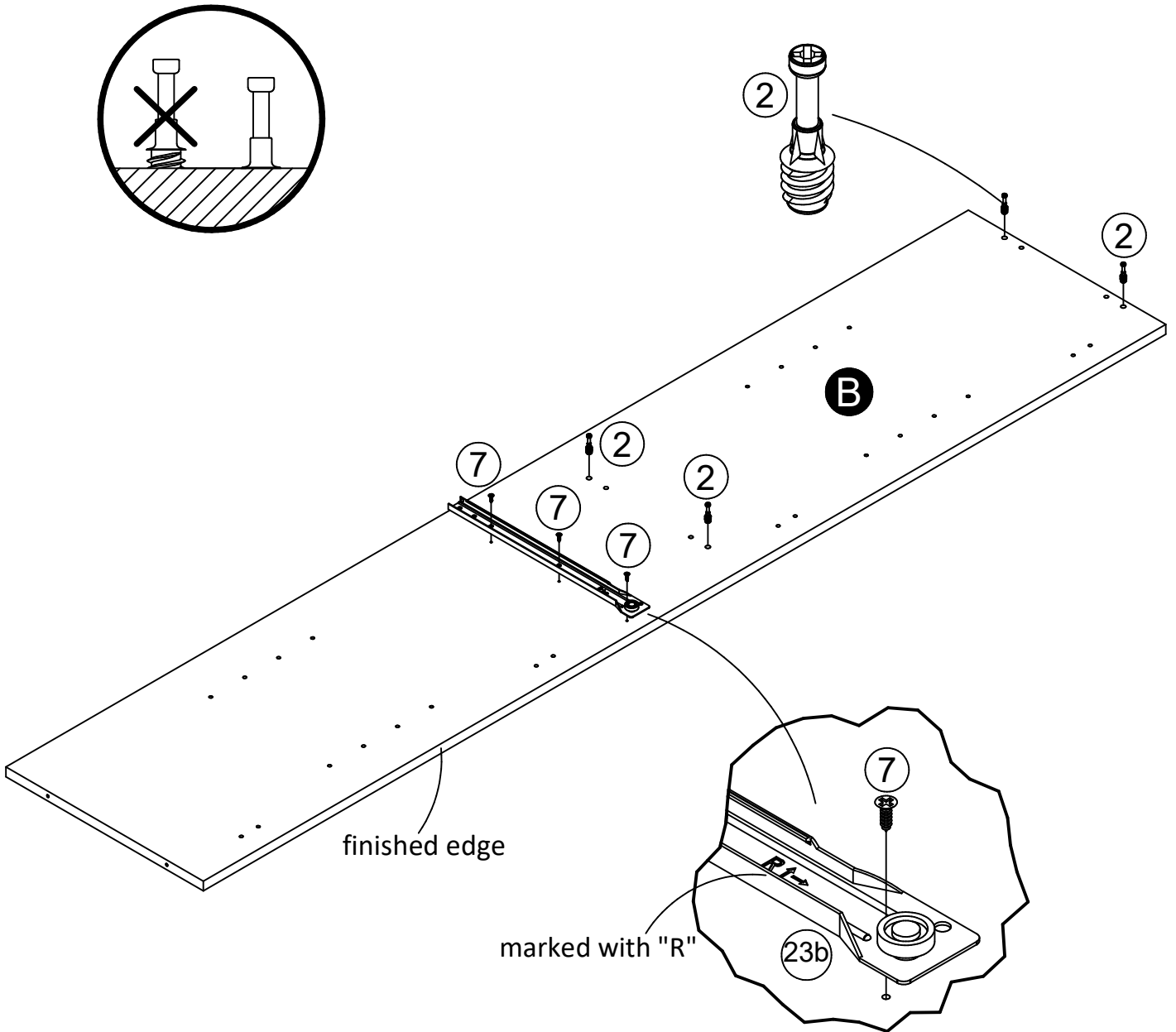
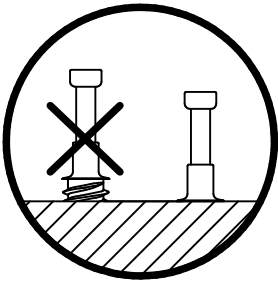
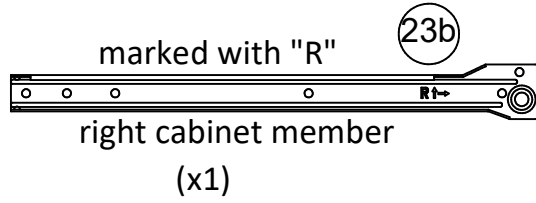
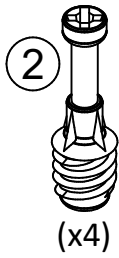
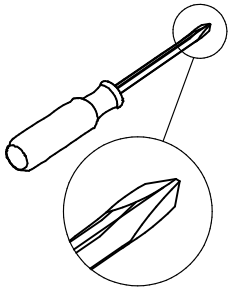

STEP 3

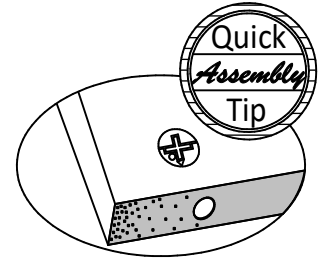
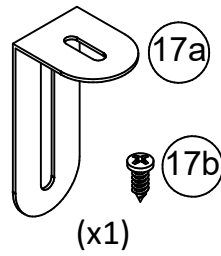
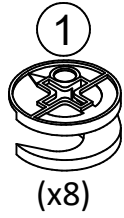
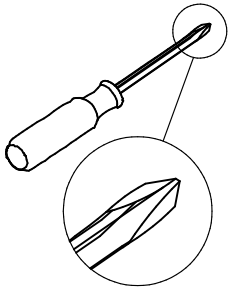

Proper orientation of CAM LOCK

Do not tighten screw.

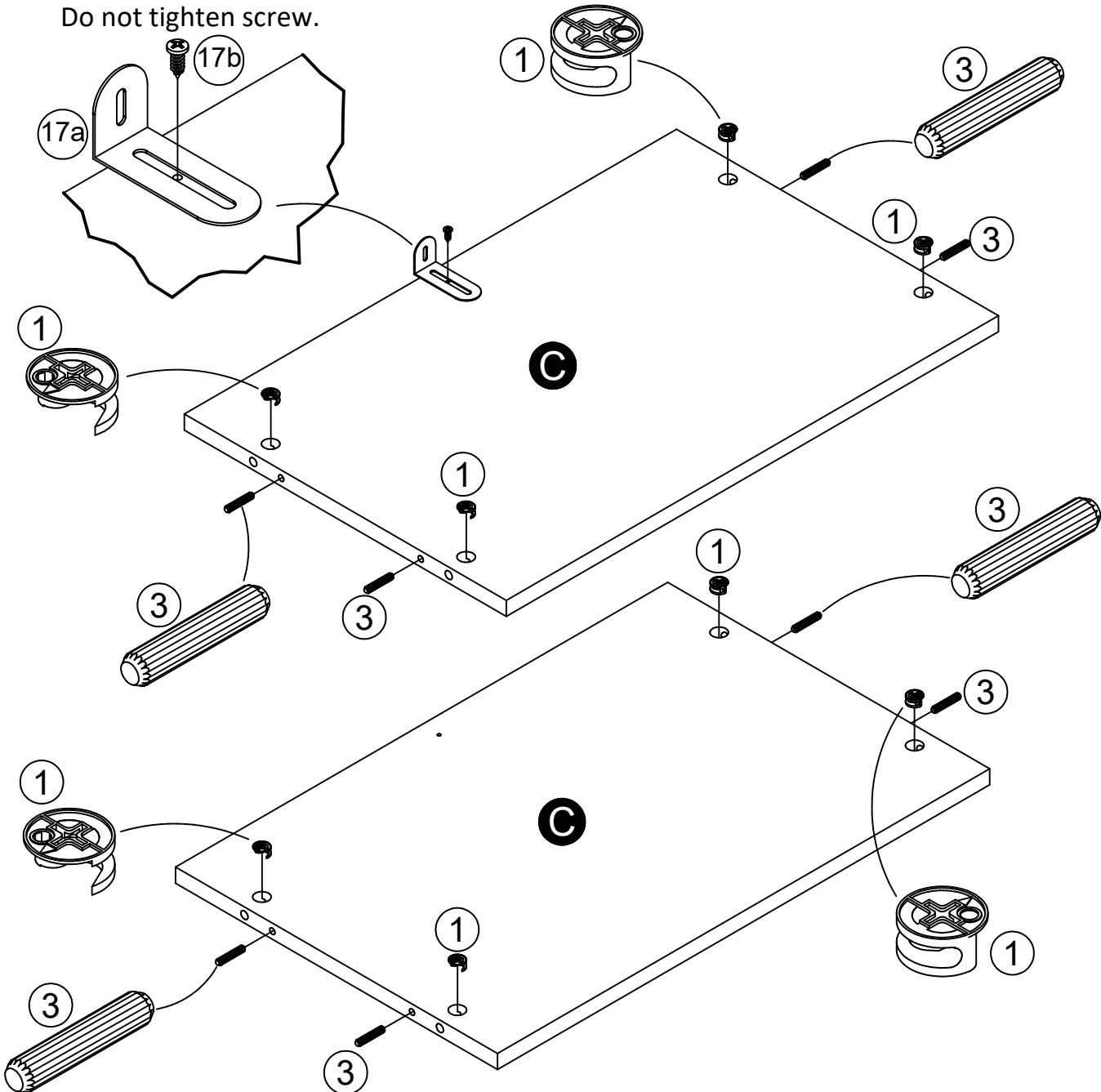

STEP 4

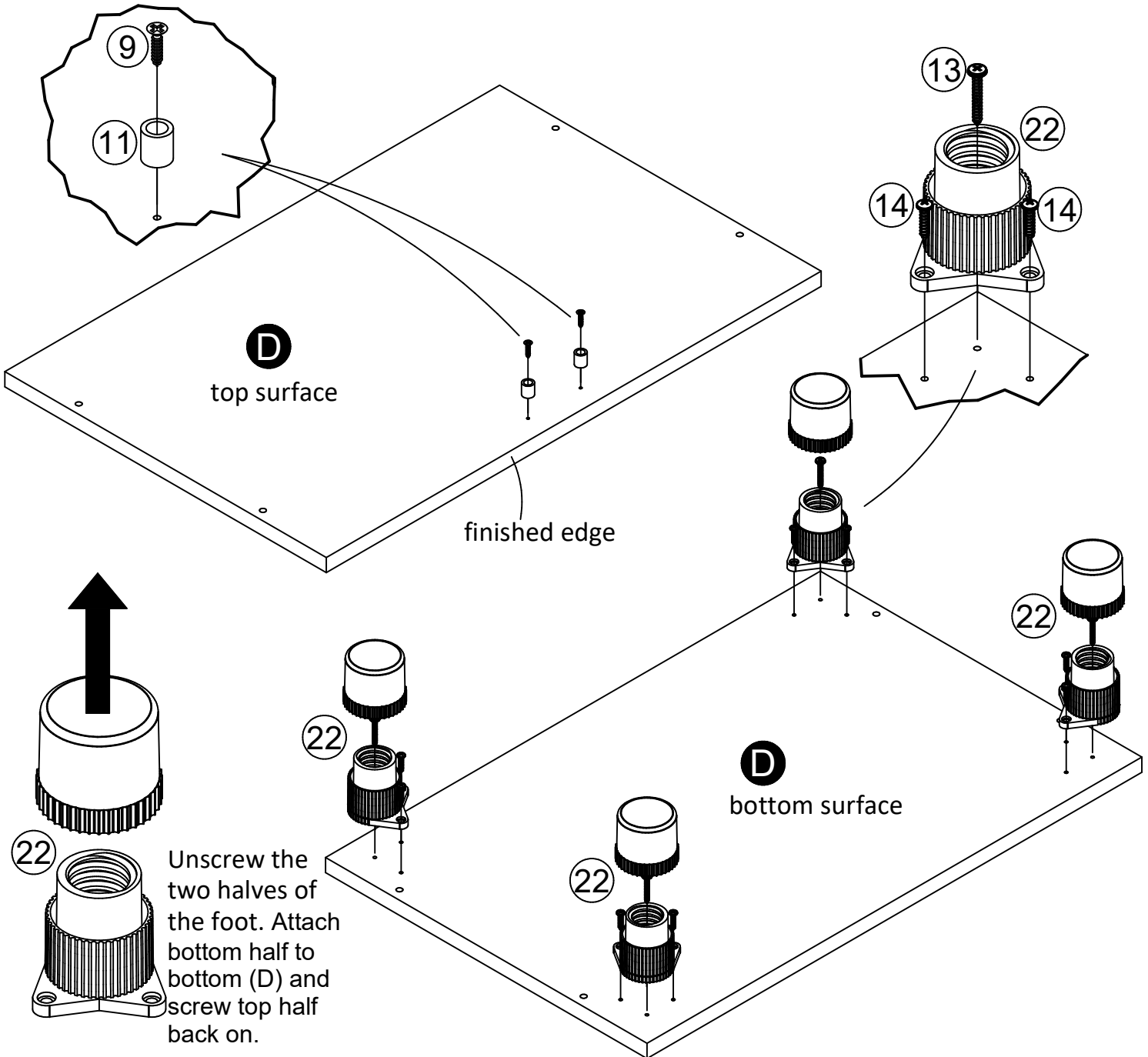
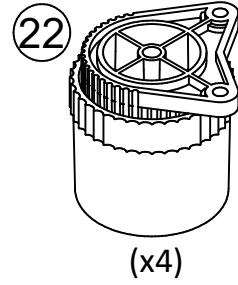
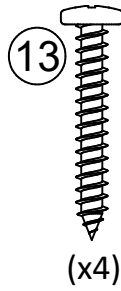
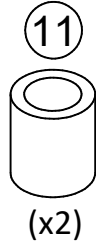
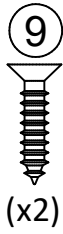
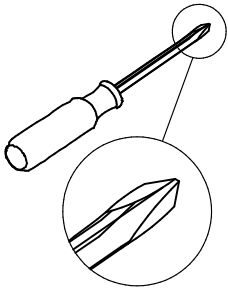

STEP 5

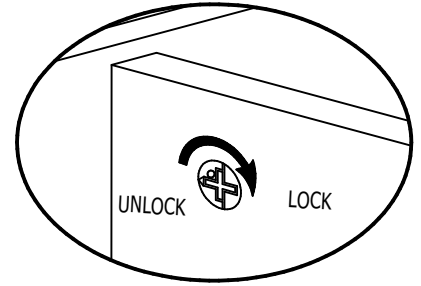
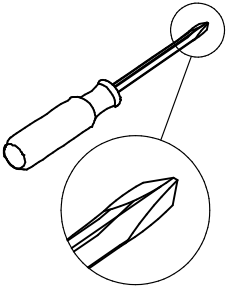

All finished edges will face up.

Cam locks (1) on top surface.

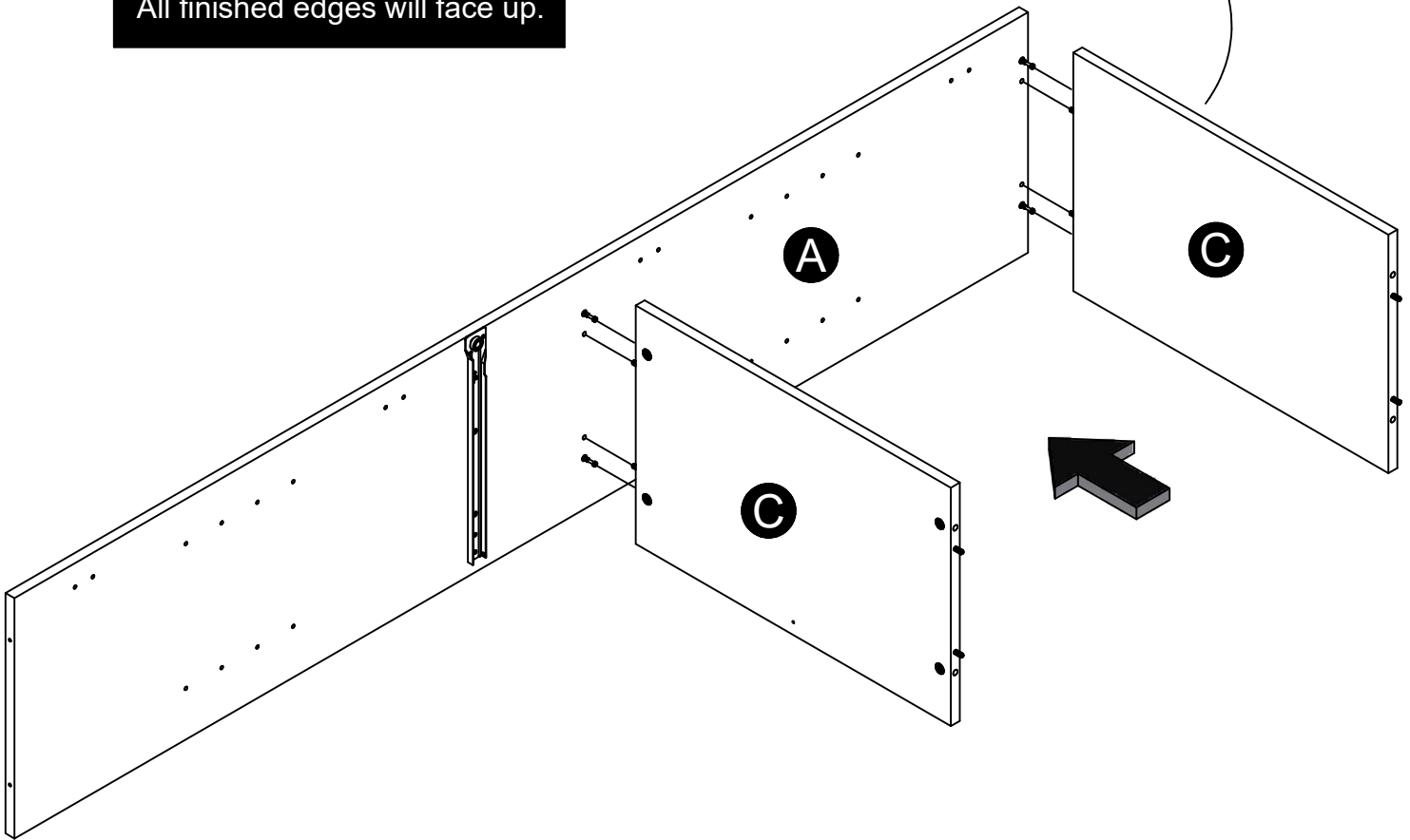

STEP 6

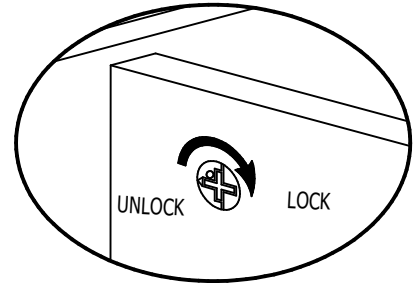
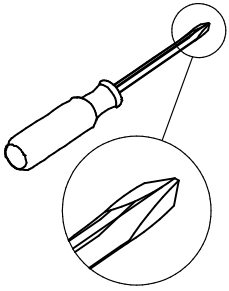

All finished edges will face up.

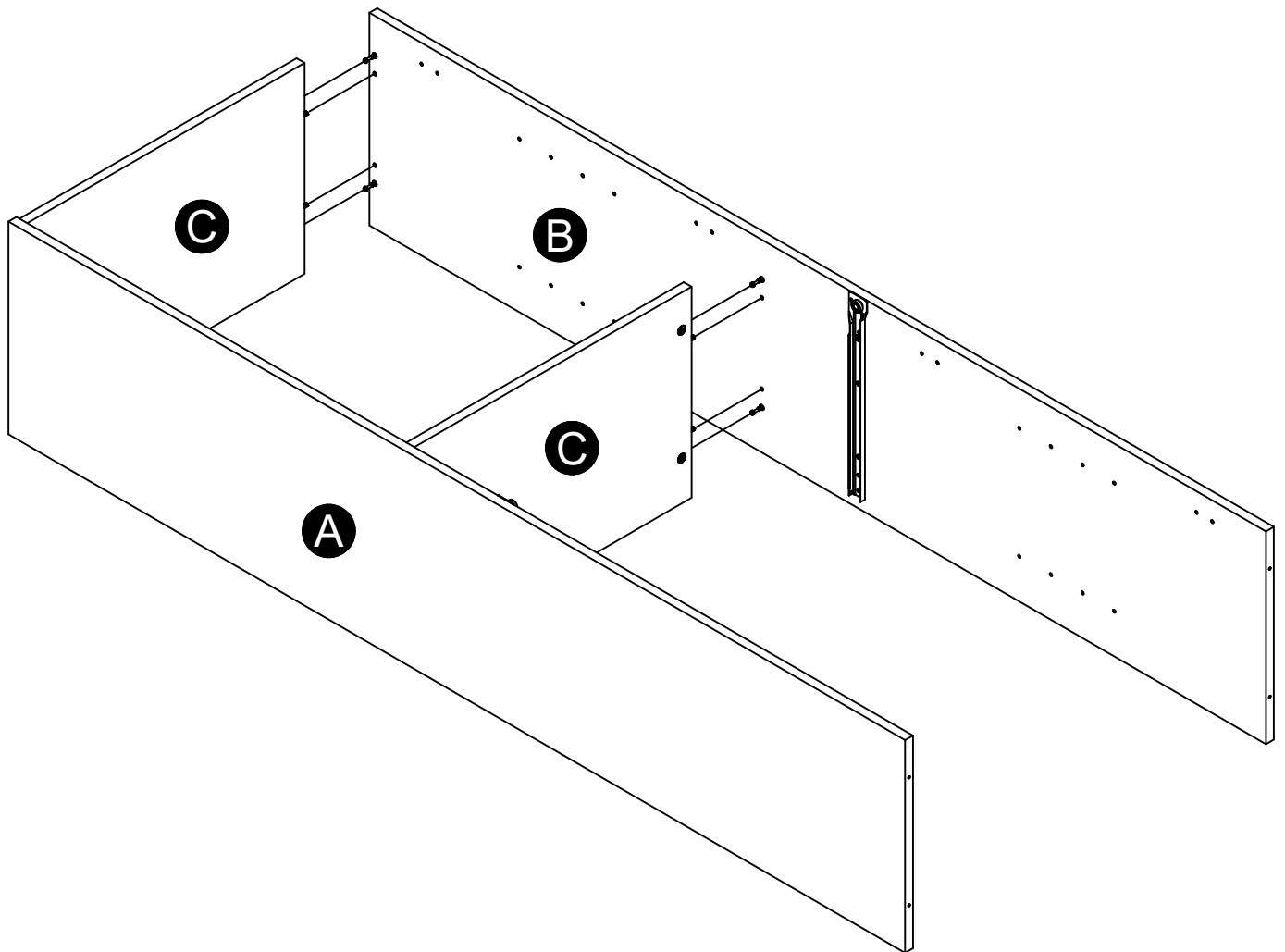

STEP 7

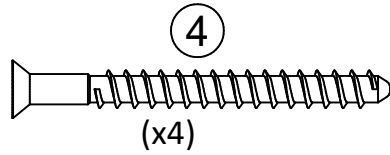
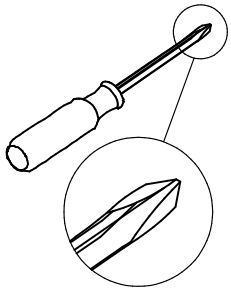

All finished edges will face up.

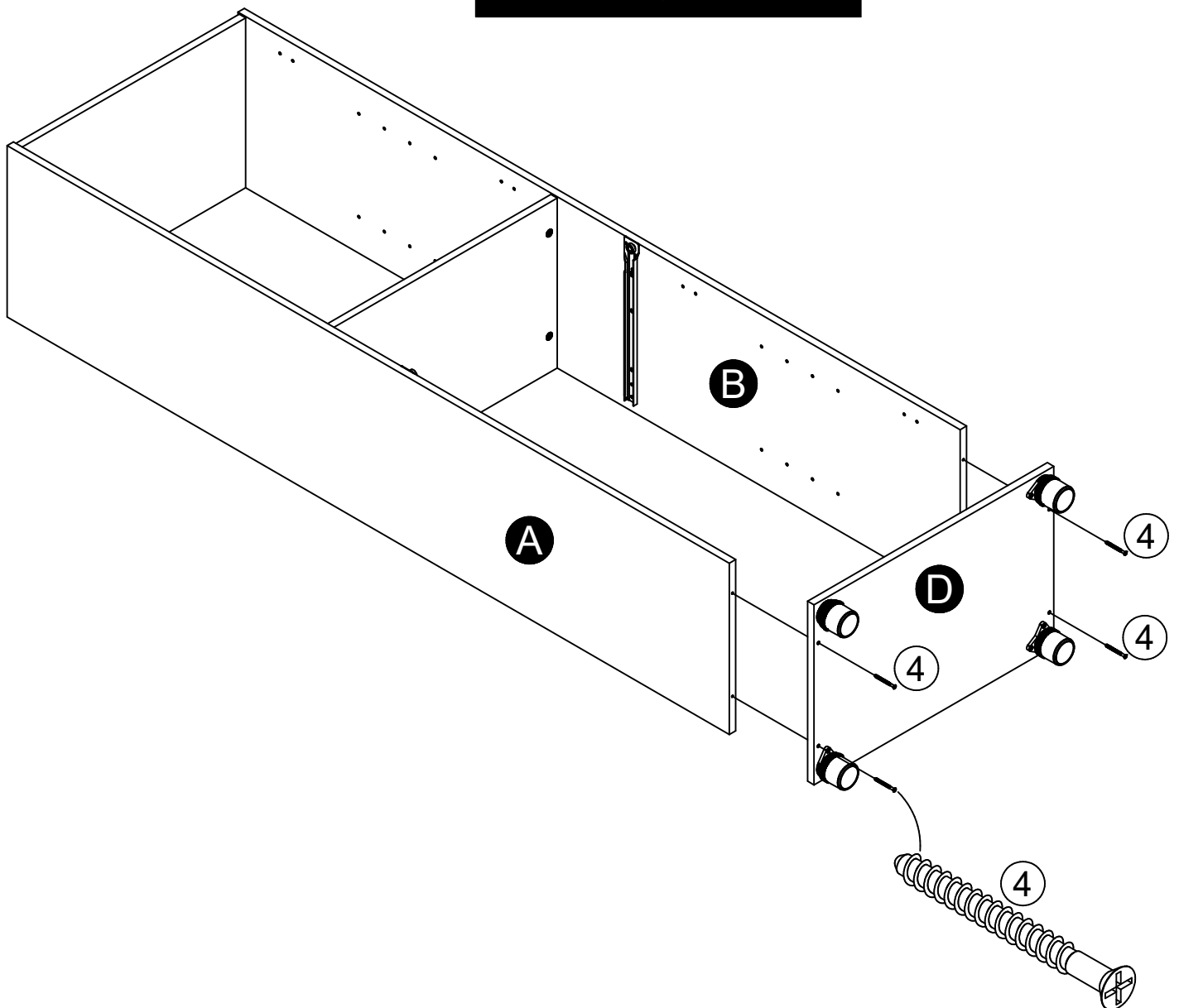

STEP 8

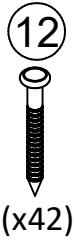
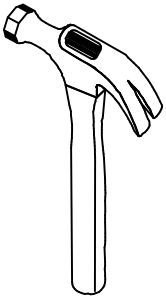

IMPORTANT! THE BACK PANEL IS A STRUCTURAL PART OF THIS UNIT AND MUST BE INSTALLED PROPERLY.

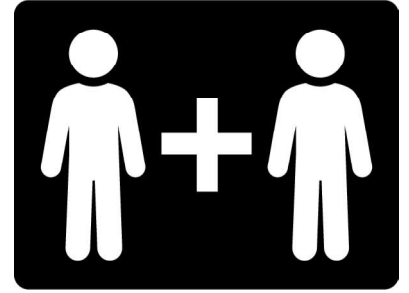

With the help of another person, turn your unit over on its front side as shown. Position the back panel as shown. Align squarely with all outer edge. Assure that your unit is square. Distance from corner to corner must be equal as shown. Attach the back panel as shown nailing straight into the raw edges.

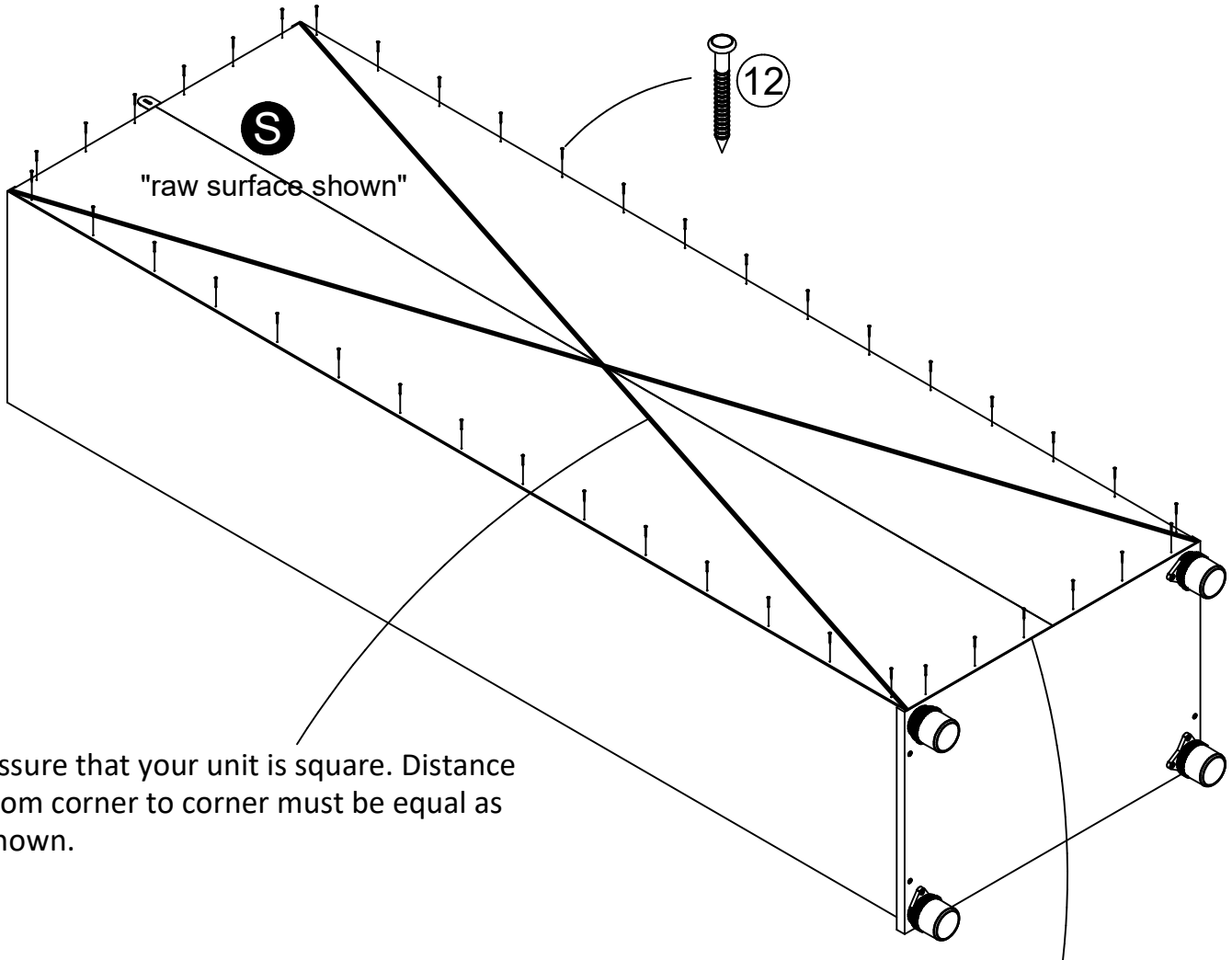

Assure that your unit is square. Distance from corner to corner must be equal as shown.

Flush the bottom edge of the back panel with the bottom edge of the bottom (D).

STEP 9

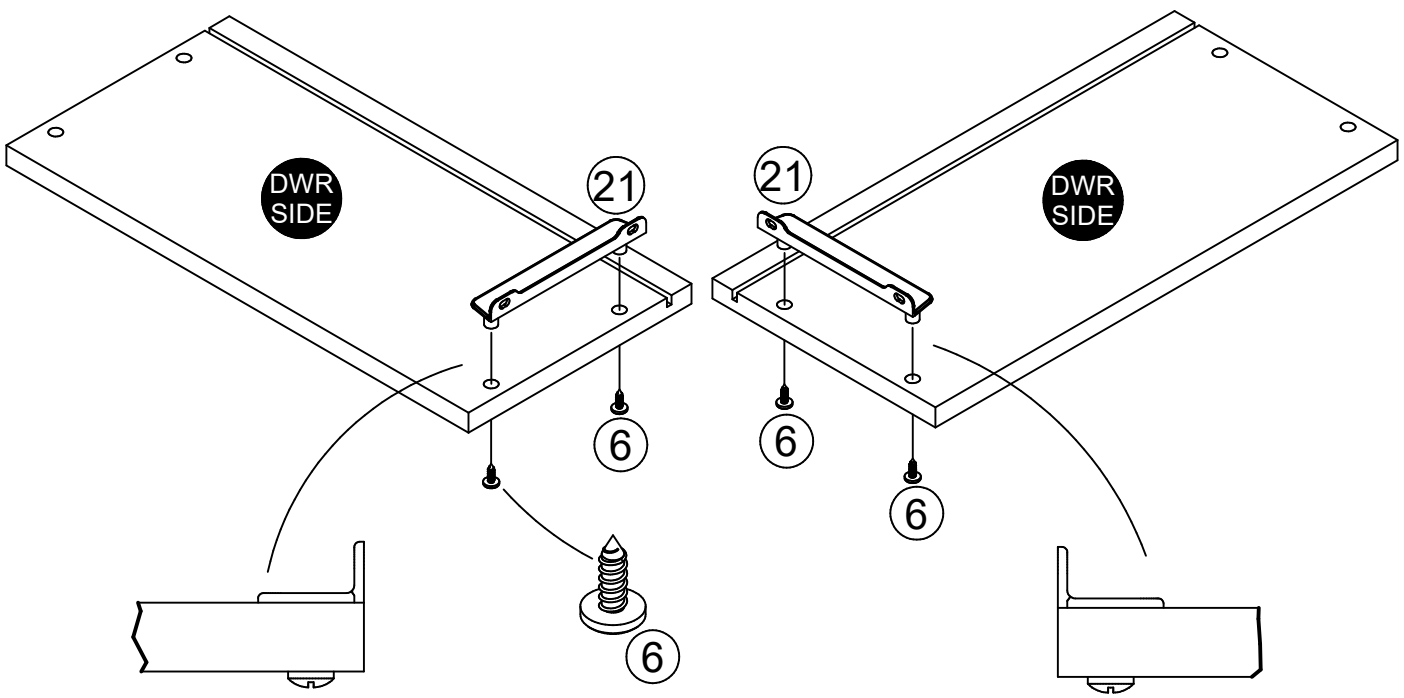
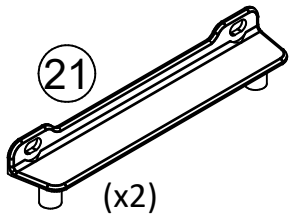
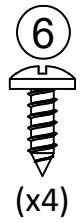
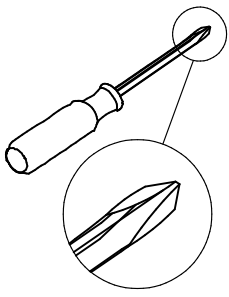

STEP 10

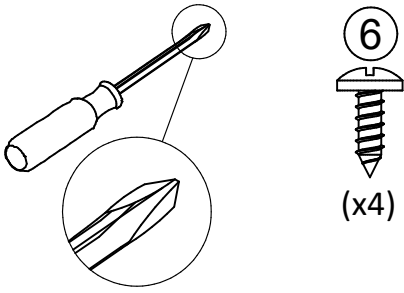

Be sure the groove in the drawer sides are centered with the groove in the drawer front.

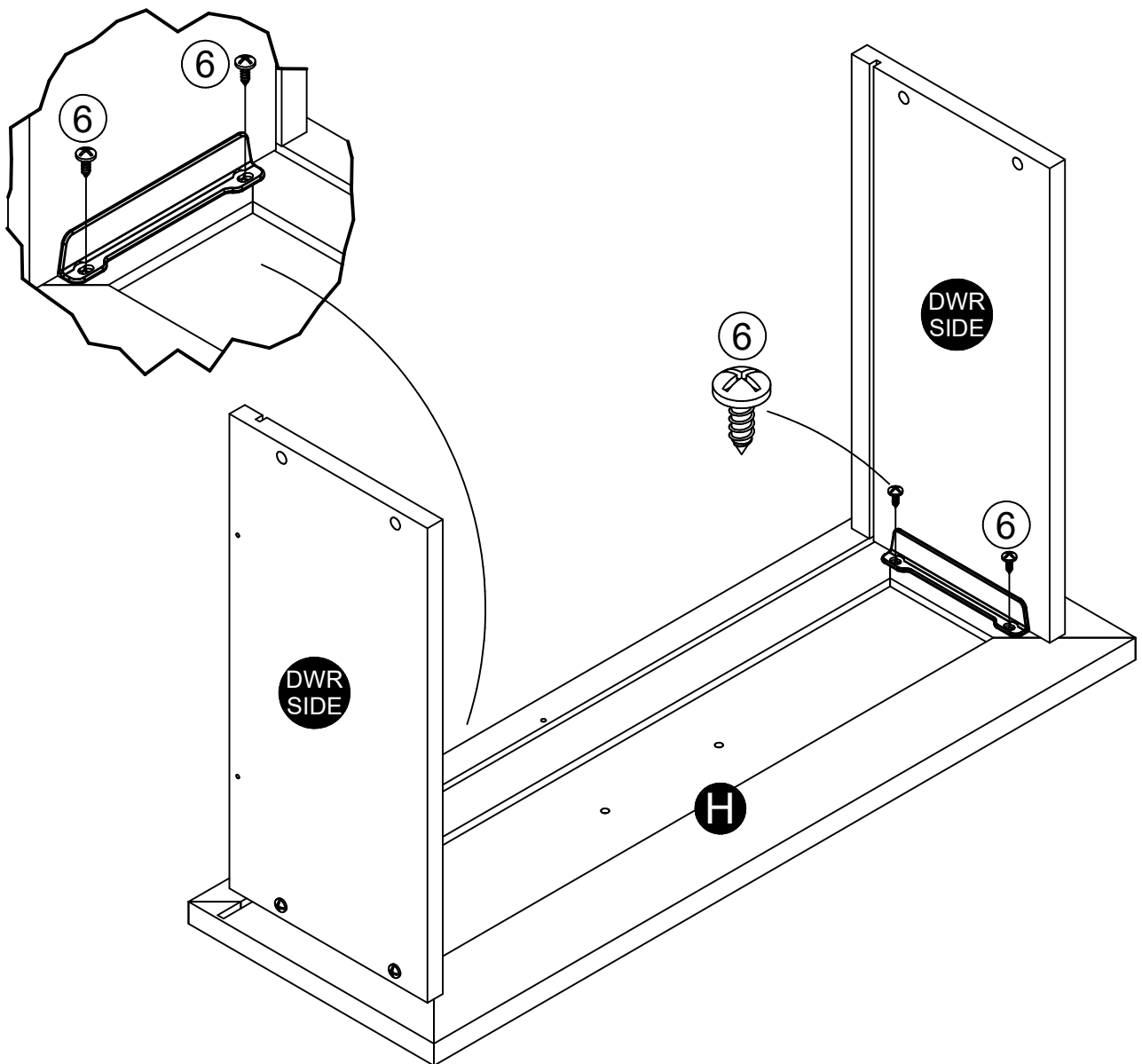

STEP 11

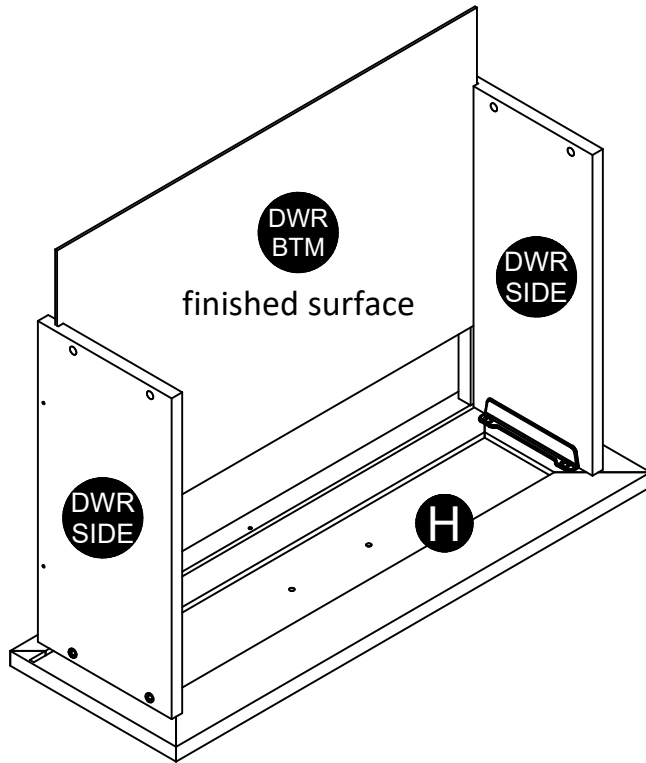

STEP 12

You will need to tap the drive fasteners (8) lightly with a hammer to securely fasten.

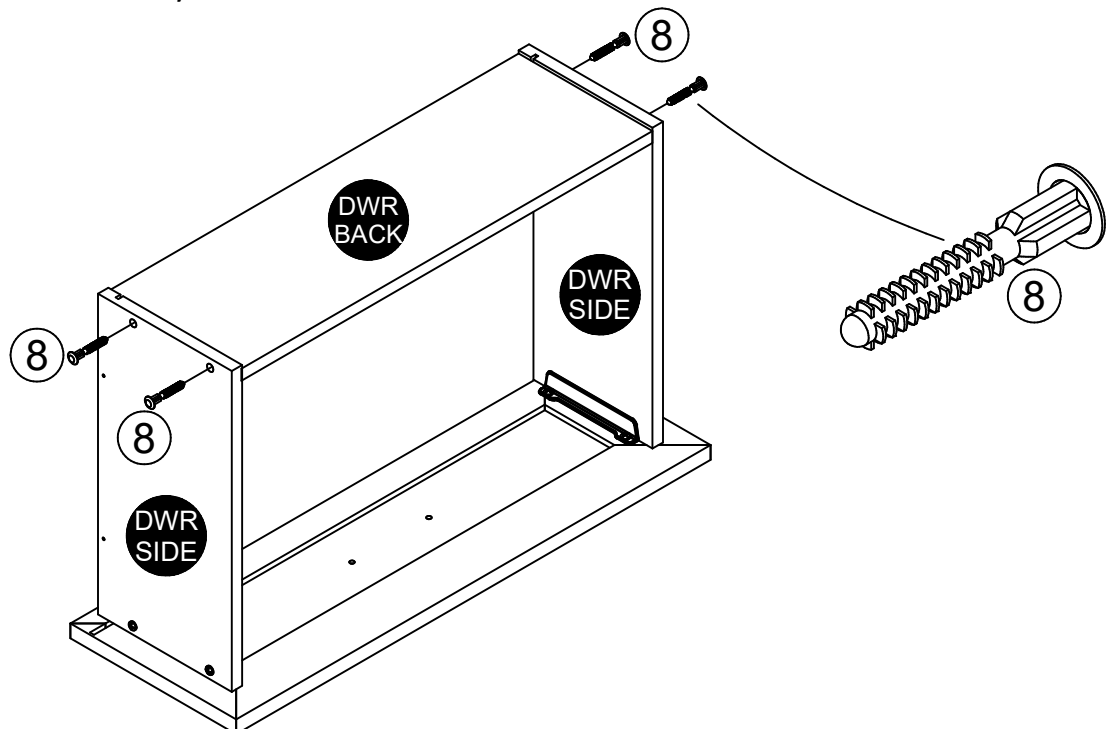
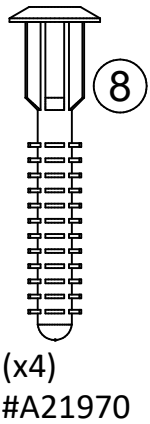

STEP 13

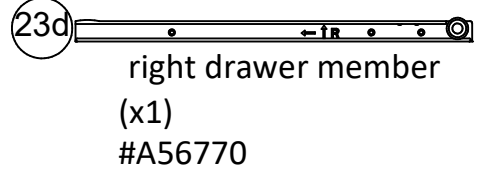
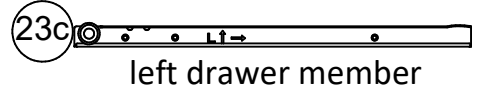
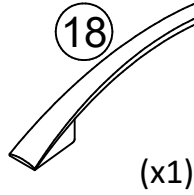
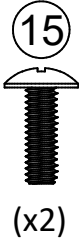
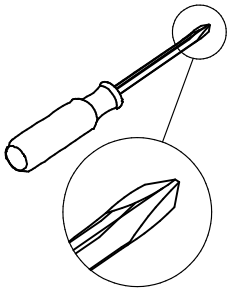

Note: Attach slides (23c&23d) first then attach handle.

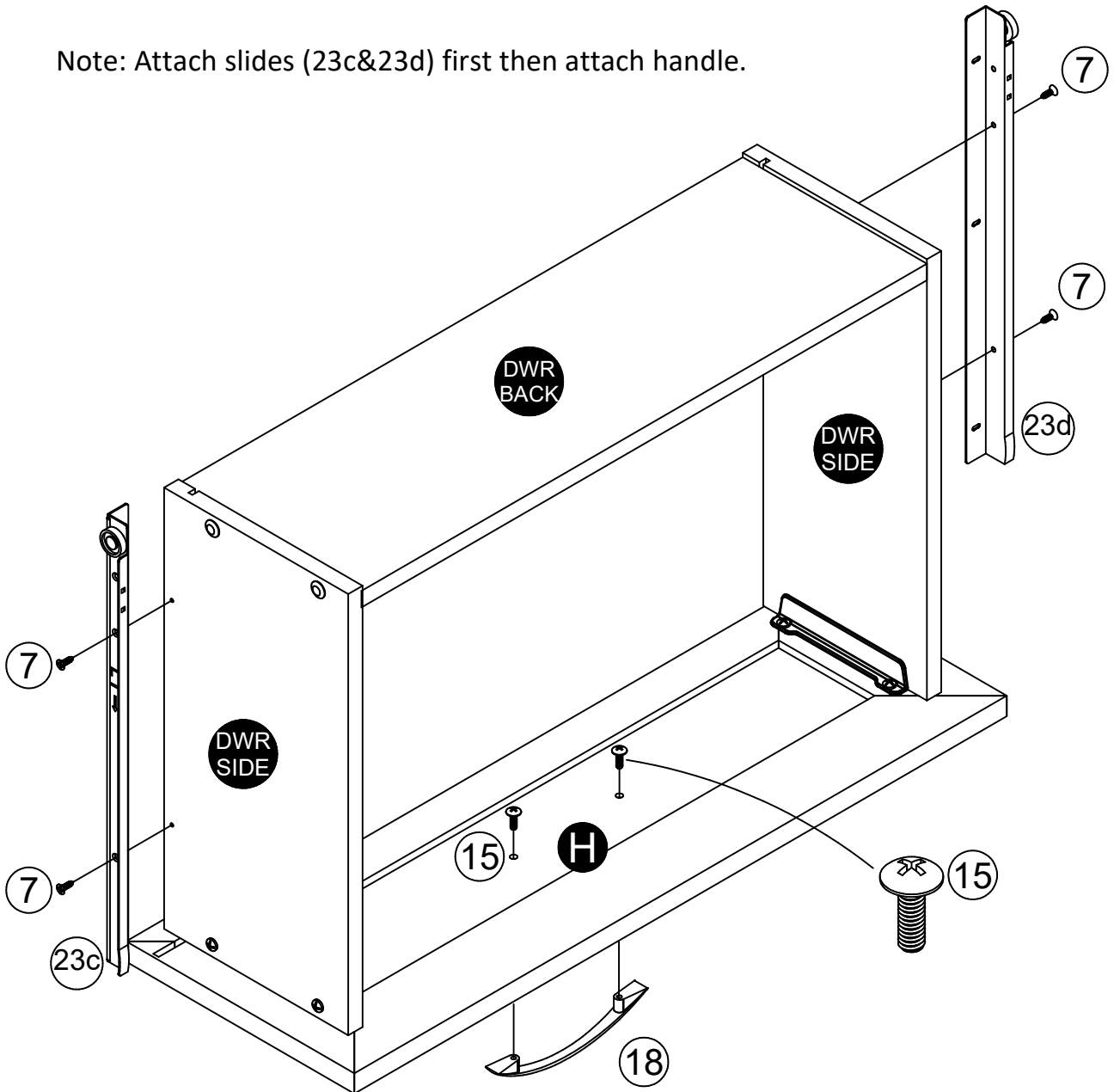

STEP 14

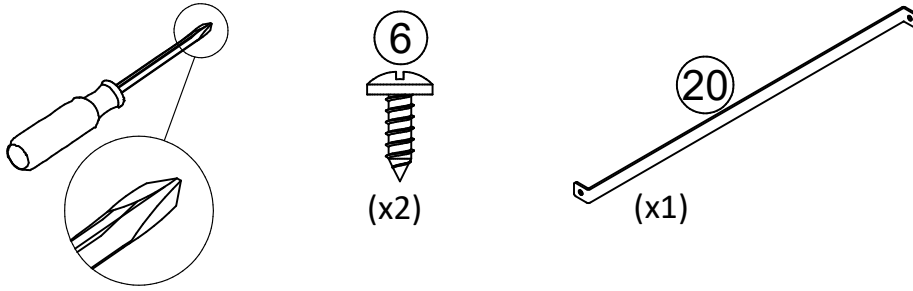

Turn drawer over. Using two screws (6), attach the drawer brace (20) as shown.

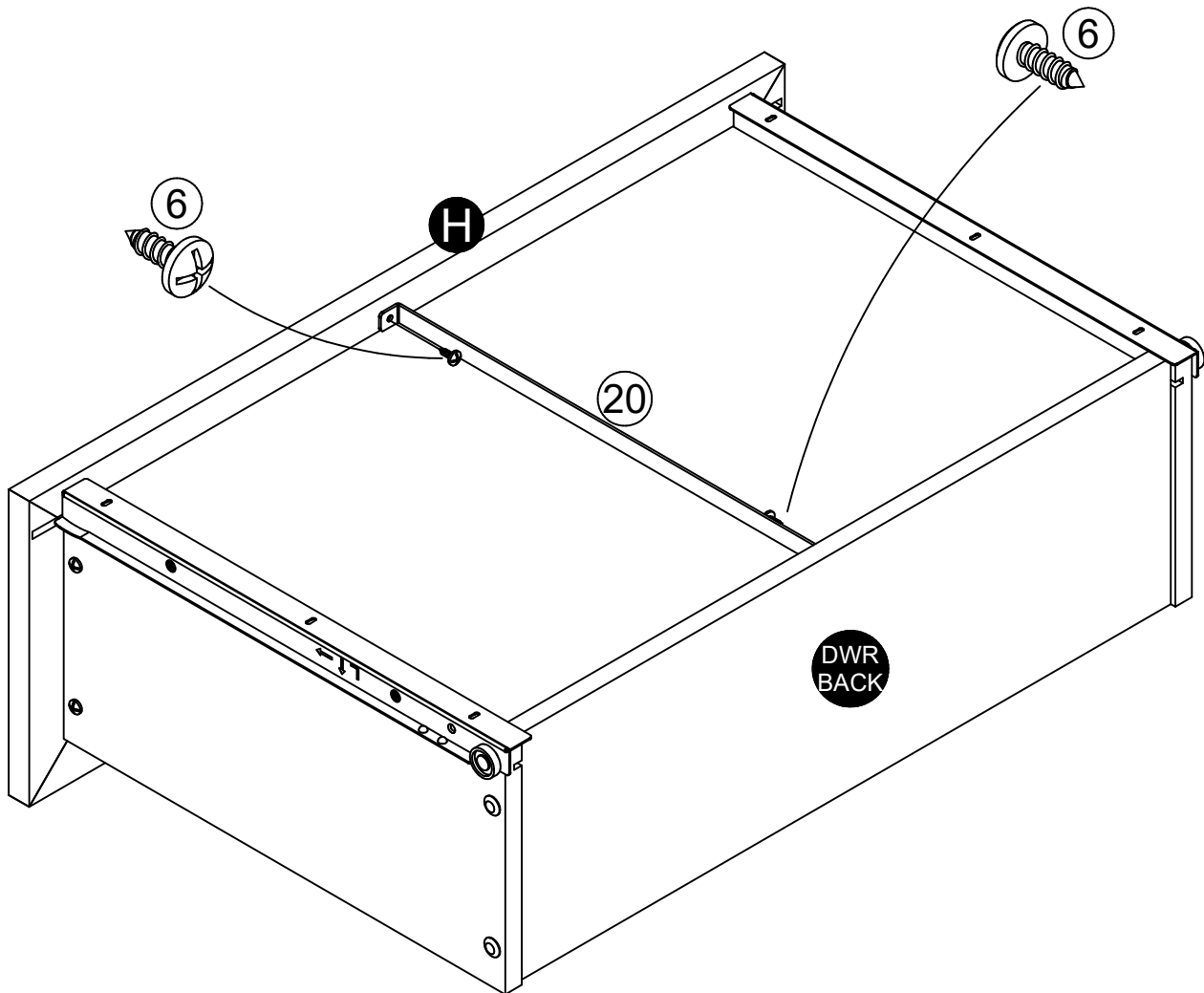

STEP 15

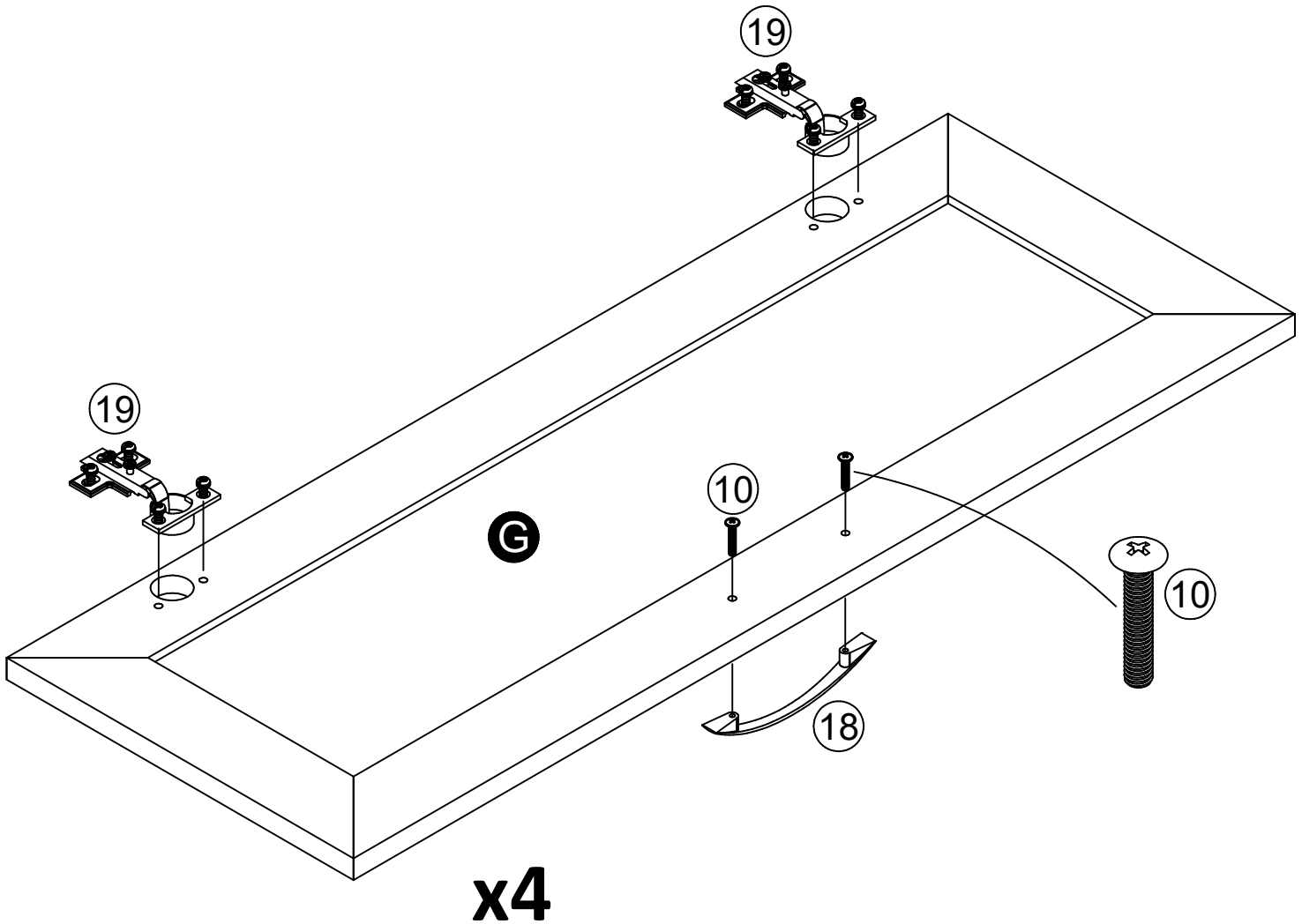
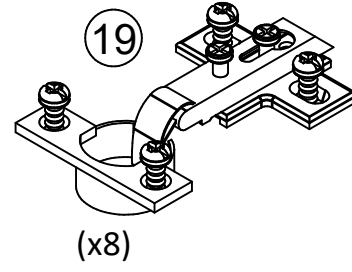
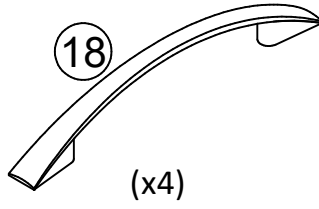
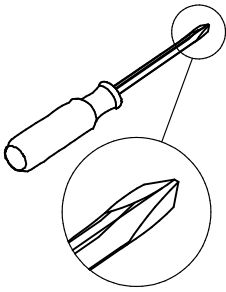

STEP 16

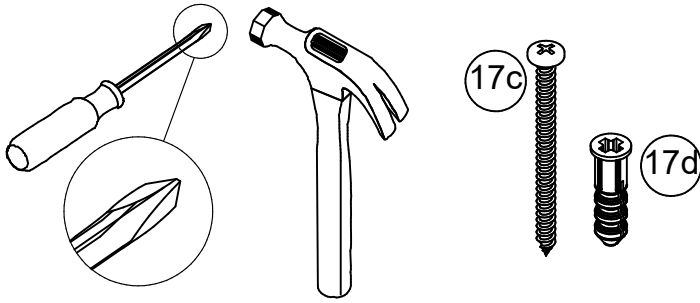

For Masonry, Concrete, or other wall materials:

Consult your local hardware store for appropriate anchors to securely attach the safety bracket.

IMPORTANT: THIS UNIT MUST BE SECURE TO THE WALL TO HELP PREVENT TIPOVER. FOLLOW THESE INSTRUCTIONS TO INSTALL THE ANTI-TIPPING SAFETY BRACKET PROVIDED WITH THIS PRODUCT. MAKE SURE UNIT IS LEVEL BEFORE SECURING TO THE WALL.

OPTION 1: Attachment into a wall stud (preferred method)

Using a stud finder, locate a stud in the wall. Place your unit against the wall, with the safety bracket aligned in this location. To make driving the screw easier, you can drill a 1/8" diameter pilot hole (3mm) through the safety bracket into the stud. Drive the screw through the safety bracket into the wall stud. Tighten the screw that was not fully tightened in step 4.

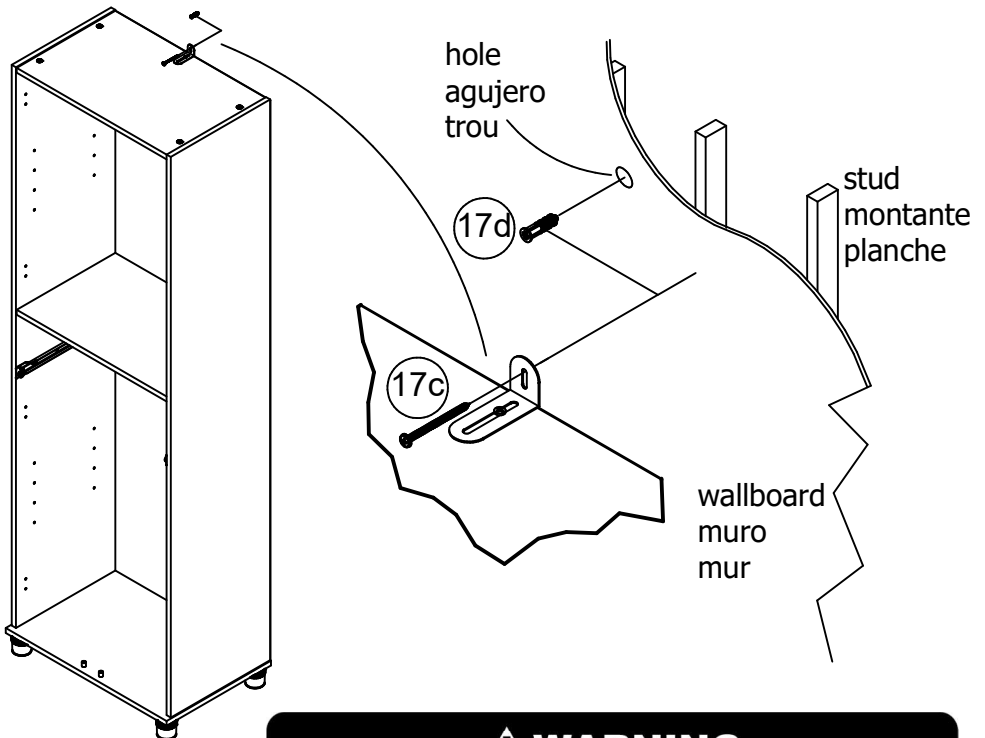

OPTION 2: Attachment into drywall

Locate your unit where desired against a wall and mark the wall through the safety bracket, then move your unit aside. Drill a 3/16" diameter hole (5mm) into the wallboard. Tap the wall anchor into the hole until it is flush. Move your unit into location and fasten the wall bracket to the wall anchor with the screw. Tighten the screw that was not fully tightened in step 4.

⚠ WARNING



Children have died from furniture tip over. To reduce the risk of furniture tip over:

- ALWAYS install tip over restraint provided.
- NEVER put a TV on this product.
- NEVER allow children to stand, climb or hang on drawers, doors, or shelves.
- NEVER open more than one drawer at a time.
- Place heaviest items in the lowest drawers.



STEP 17

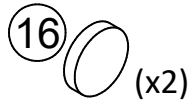
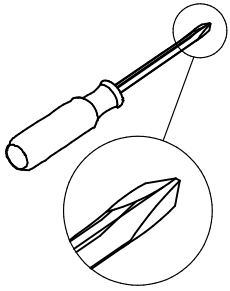

With the help of another person, attach the four doors as shown by screwing the screws from hinge plate into the side panels.
Peel and stick bumpers (16) onto front edge of top shelf where top doors (G) meet.

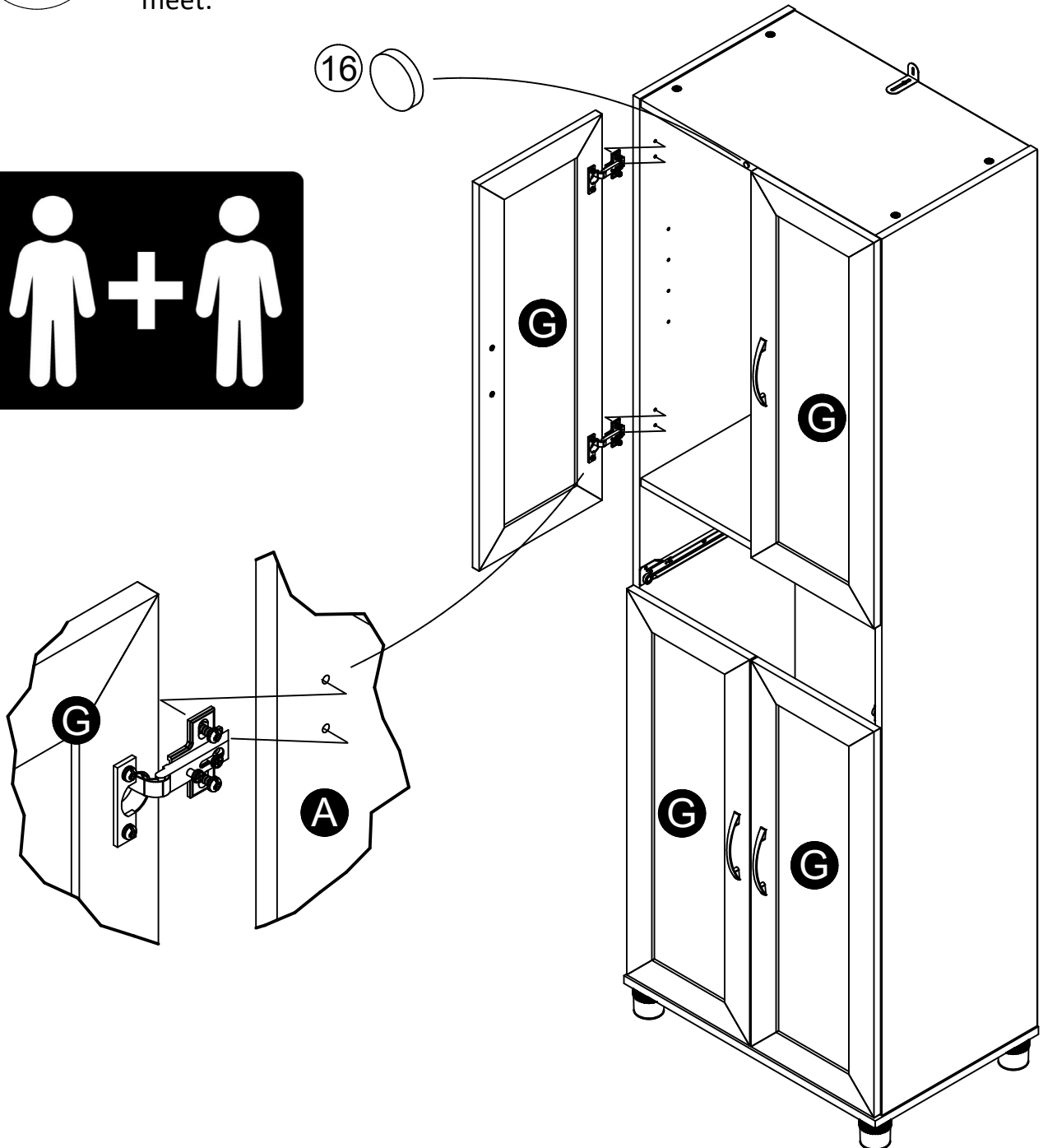
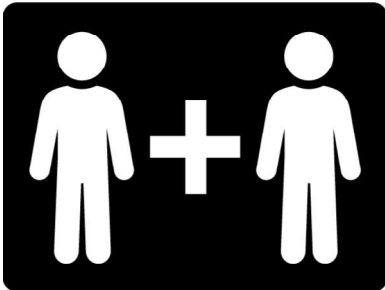

STEP 18

Install the drawer as shown below. Follow adjustment details below to adjust drawer.

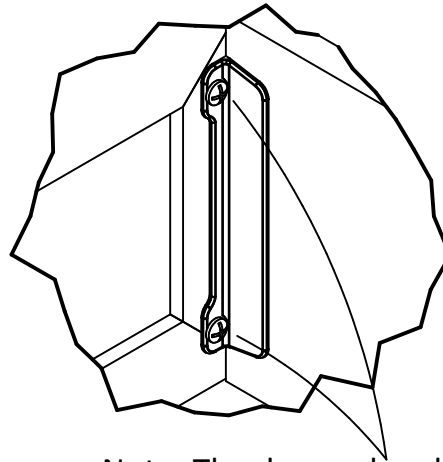
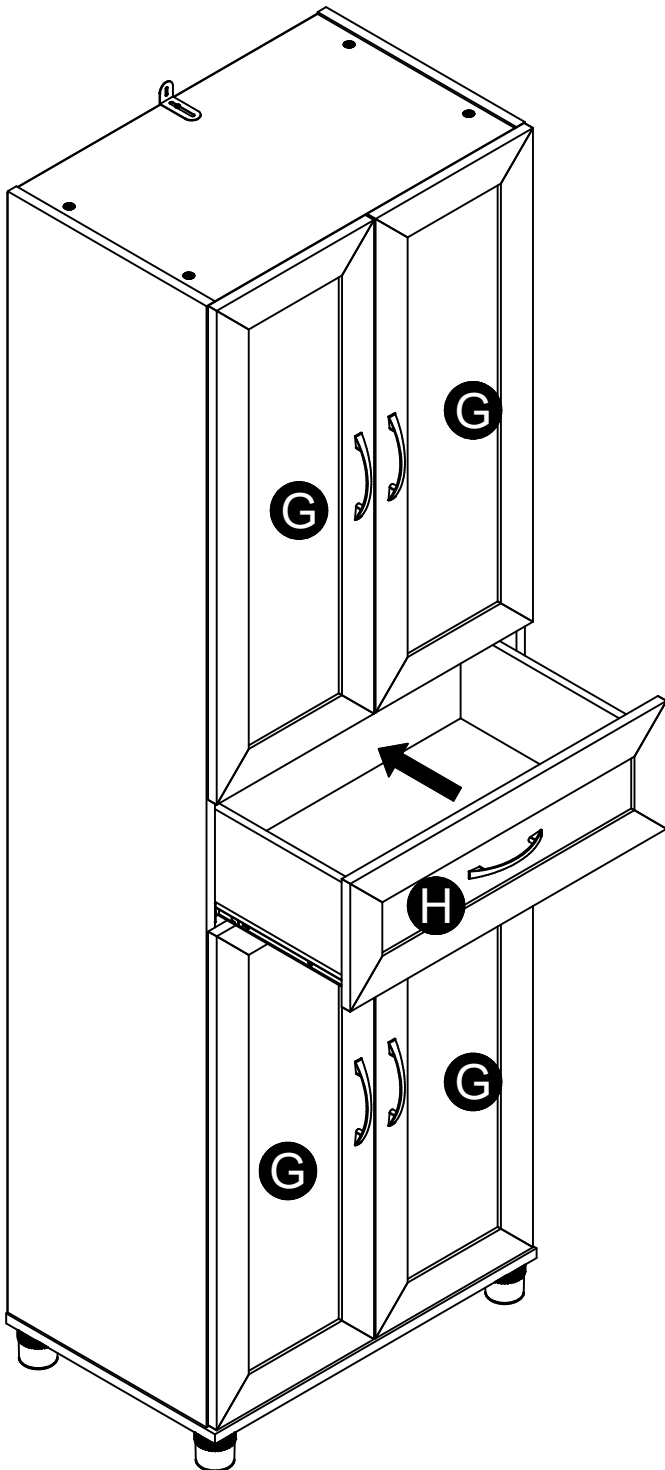

Note: The drawer bracket holes are slotted. Drawer front can be adjusted by loosening screws, making needed adjustments and retightening screws.

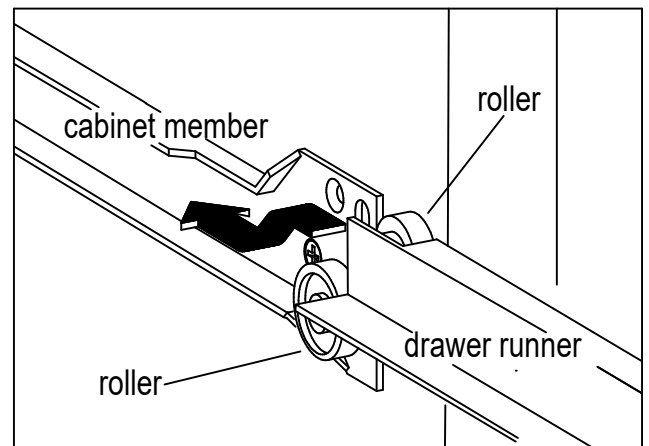

STEP 19

Door Adjustment

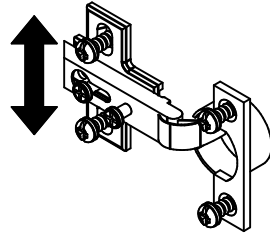
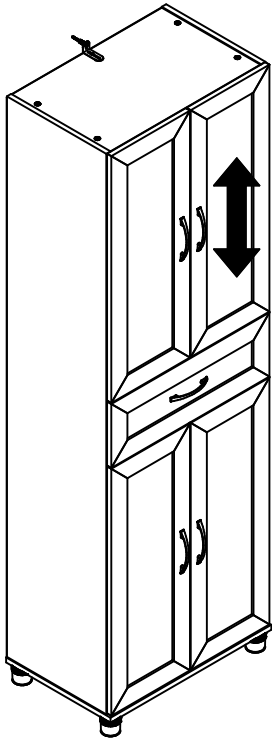

To adjust the vertical height:
Loosen the screws "A" on both hinges. They are usually in slotted holes which allows you to adjust up or down by a few mm. Then tighten back up.

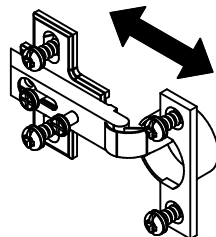
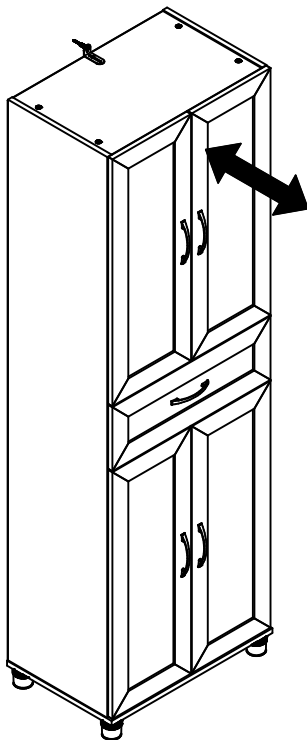
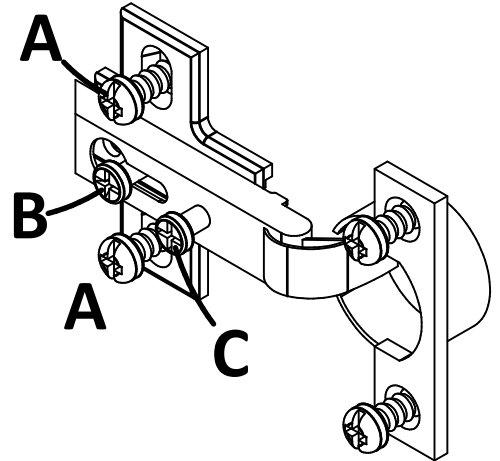

To adjust the depth:
Loosen the screw "B" and adjust door.

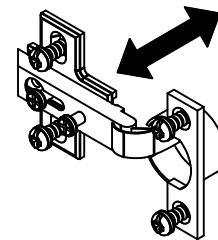
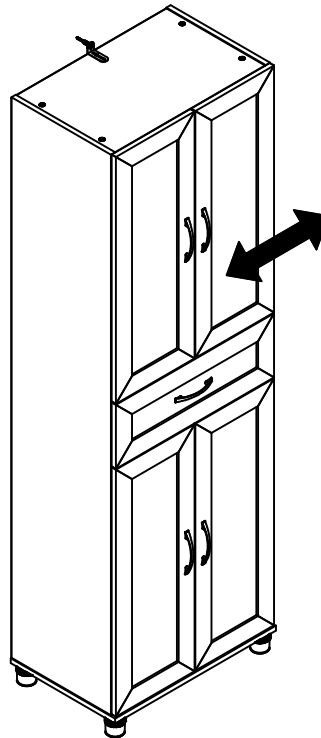

To adjust side to side:
Loosen the screw "C" on BOTH hinges and tighten "B" moves door outward. Loosen "B" and tighten "C" moves doors inward.

STEP 20



(x8)
#A80250

Using the shelf supports (5), place an adjustable shelf (F) behind each door area.

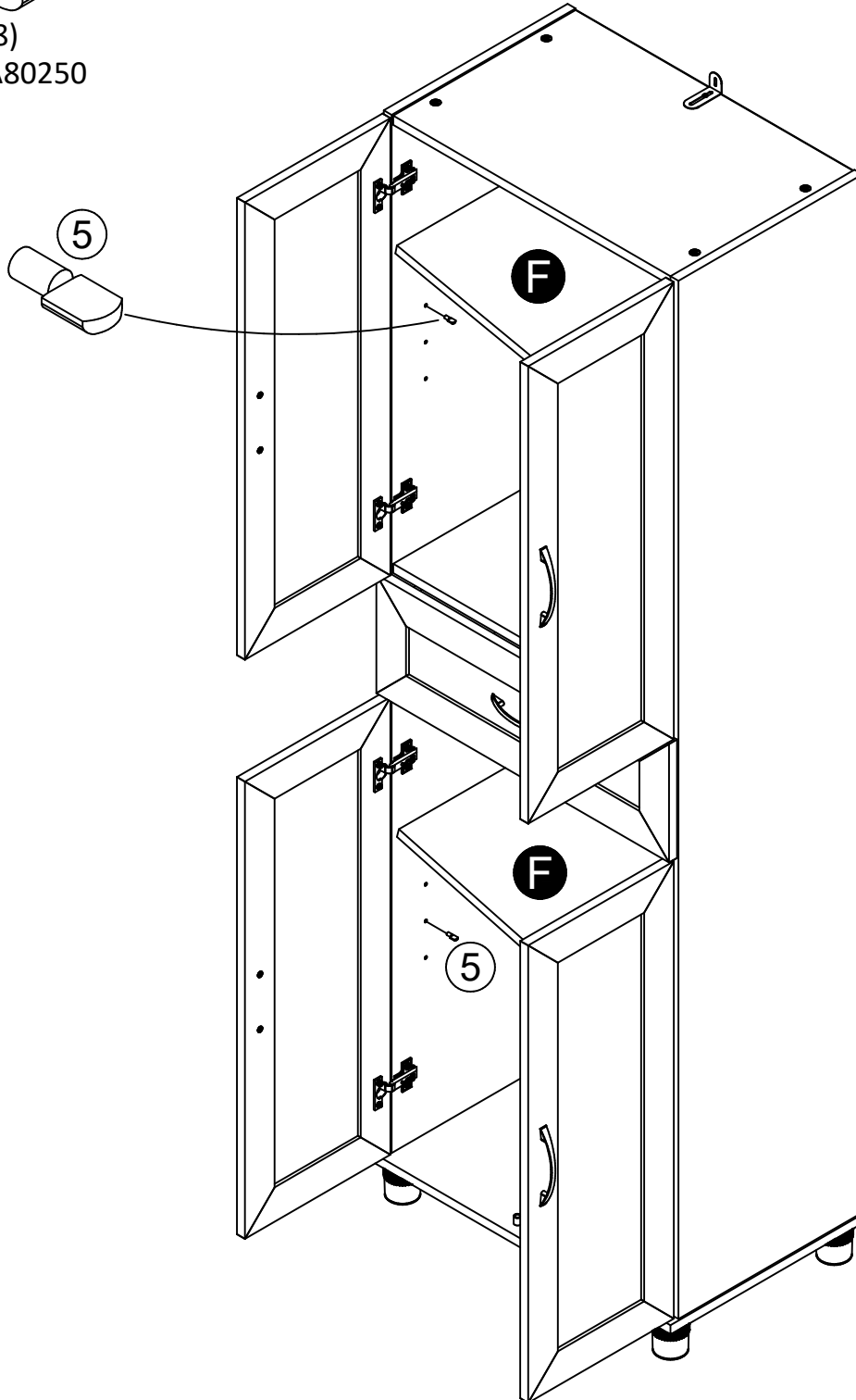

Maximum Loads

This unit has been designed to support the maximum loads shown. Exceeding these load limits could cause sagging, instability, product collapse, and/or serious injury.

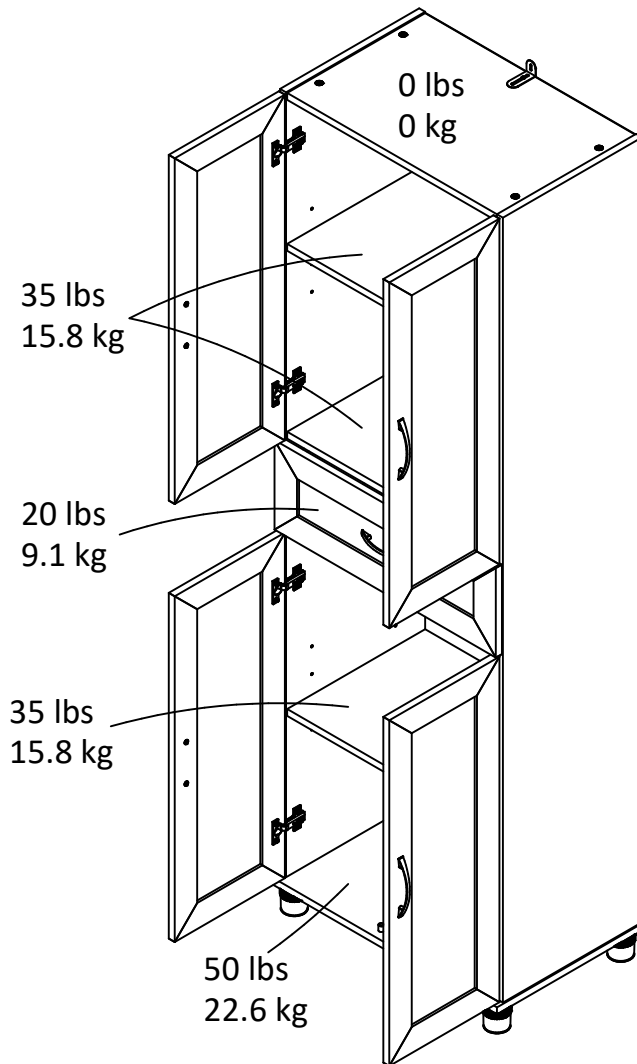

Warning: Risk of injury to persons - do not place a television on this furniture. This furniture is not approved for use with a television.

Certificate of Conformity

1. This certificate applies to the Dorel Home Furnishings, Inc. product identified by this instruction manual.
2. This certificate applies to compliance of this product with the CPSC Ban on Lead-Containing Paint (16 CFR 1303).
3. This product is distributed by: Dorel Home Furnishings, Inc.
410 East First Street South
Wright City, MO 63390
636-745-3351
4. Site of Manufacture: Tiffin OH
5. See front page of instruction manual for date of manufacture.

Register your product to receive the following:



- * New trend details - sneak peek on what's new
- * Surveys - have a voice within our community
- * Exclusive deals and discount codes
- * Quick and easy replacement part service

To register your product, visit systembuild.com

5 Star Rating



Visit your local retailer's website, rate your purchased product and leave us some feedback!

We would like to extend a big "Thank You" to all of our customers for taking the time to assemble this Systembuild product, and to give us your valuable feedback.

*Thank
You!*

Cubierta Delantera

Este libro de instrucciones contiene información **IMPORTANTE** de seguridad. Por favor lea y manténgalo para referencia en el futuro.

No Regrese este producto! Comuníquese con nuestro amistoso equipo de servicio al cliente para obtener ayuda.

Llámenos al: 1-866-452-4081 (Gratis) Lunes - Viernes 9am - 5pm CST

Visitar: www.systembuild.com

PRECAUCION

Este mueble puede volcarse y causar graves heridas y/o muerte.

Anclar el mueble a un poste de madera en la pared (si esto se requiere).

No Permita que los niños monten el mueble.

Mantenga los artículos más pesados en los cajones de abajo.

Consejos Útiles (página 2)

- Abra su artículo en el área donde usted planea utilizarlo para evitar levantar y moverlo menos
- Identificar, ordenar y contar las piezas antes de intentar ensamblar
- Las clavijas de compresión se golpean con un martillo
- Las diapositivas están marcadas con una R (derecha) y L (izquierda) para la colocación correcta
- Asegúrese de que siempre este el punto localizado en la parte superior de bloqueador de leva este volteado hacia borde exterior
- Utilizar todos los clavos para el panel de atrás y distribuirlos por igual
- El panel de atrás debe utilizarse para asegurarse de que la unidad quede fija y firme
- No use químicas fuertes ni limpiadores abrasivos en este artículo
- Nunca empuje, tire ni arrastre los muebles

Antes de Que Empieces (página 3)

- Lea cuidadosamente cada paso y siga el orden correcto

- Separar y contar todas sus piezas y hardware

- Dése suficiente espacio para el proceso de ensamble

- Tenga las siguientes herramientas: destornillador de cabeza plana, #2 cabeza Phillips

Destornillador y martillo

- Precaución: Si usa un taladro electrónico o un destornillador eléctrico para atornillar, por favor asegúrese que deje de atornillar cuando el tornillo este apretado. Fallar hacer esto puede causar barrer el tornillo.

Sistema de fijar el bloqueo de leva (página 3)

Este sistema de fijar el bloqueo de leva sera usado en todo el proceso ensamble.

Página 12

Desenrosque las dos mitades del pie. Fije la mitad inferior a la parte inferior (D) y atornille en la mitad superior.

Página 13

Cerraduras de leva (1) en la superficie superior.

Página 16

¡IMPORTANTE! EL PANEL POSTERIOR ES UNA PARTE ESTRUCTURAL DE ESTA UNIDAD Y DEBE INSTALARSE DE MANERA ADECUADA.

Con la ayuda de otra persona, dé vuelta su unidad sobre su lado frontal tal como se muestra. Coloque el panel posterior como se muestra. Alinee directamente con todo el borde exterior. Asegúrese de que su unidad esté en escuadra. La distancia de esquina a esquina debe ser igual a como se muestra. Fije el panel trasero como se muestra clavándolo directamente en los bordes sin tratar.

Asegúrese de que su unidad esté en escuadra. La distancia de esquina a esquina debe ser igual a como se muestra.

Alinee el borde inferior del panel posterior con el borde inferior de la parte inferior (D).

Página 18

Asegúrese de que la ranura en los lados del cajón se centre con la ranura en la parte frontal del cajón.

Página 19

Tendrá que golpear ligeramente los clavos sujetadores (8) con un martillo para fijarlos bien.

Página 20

Observación: Fije las correderas (23c y 23d) primero y luego fije el mango.

Página 21

Dé vuelta el cajón. Con dos tornillos (6), fije la abrazadera del cajón (20) como se muestra.

Página 23

IMPORTANTE: ESTA UNIDAD SE DEBE FIJAR A LA PARED PARA QUE NO SE VUELQUE. SIGA ESTAS INSTRUCCIONES PARA INSTALAR EL SOPORTE DE SEGURIDAD PARA PREVENIR CAIDAS QUE SE INCLUYE CON ESTE PRODUCTO.

OPCIÓN 1: Fijar en una viga en la pared (método preferido)

Usando un detector de vigas, localice una viga en la pared. Coloque la unidad contra la pared con el soporte de seguridad alineado en esta ubicación. Para hacer el atornillado más fácil puede perforar un agujero piloto de 1/8" de diámetro (3 mm) a través del soporte de seguridad en la viga. Atornille a través del soporte de seguridad en la viga de la pared. Apriete el tornillo de que no se apretó completamente en el paso 3.

OPCIÓN 2: Fijar en pared de yeso

Ubique su unidad donde lo quiera poner contra la pared y marque la pared a través del soporte de seguridad, después mueva la unidad a un lado. Perfore un agujero de 3/16" de diámetro (5 mm) en el panel de yeso. Golpee el anclaje de pared en el agujero hasta que quede al ras. Mueva su unidad en el lugar y fije el soporte de pared al anclaje de pared con el tornillo. Apriete el tornillo de que no se apretó completamente en el paso 3.

Para mampostería, concreto u otros materiales de pared:

Consulte a su ferretería local para los anclajes apropiados para fijar el soporte de seguridad firmemente.

Página 24

Con la ayuda de otra persona, conecte las cuatro puertas como se muestra atornillando los tornillos de la placa de bisagra en los paneles laterales.

Pelar y pegar parachoques (16) en el borde frontal del estante superior donde las puertas superiores (G) se encuentran.

Página 25

Instale el cajón como se muestra a continuación. Siga los detalles de ajuste a continuación para ajustar el cajón.

Nota: Los orificios del soporte del cajón están ranurados. El frente del cajón se puede ajustar aflojando los tornillos, haciendo los ajustes necesarios y reajustando los tornillos.

Página 26

Para ajustar la altura vertical:

Afloje los tornillos "A" en ambas bisagras. Por lo general, están en agujeros ranurados que le permite ajustar hacia arriba o hacia abajo por unos pocos mm. A continuación, apriete de nuevo.

Para ajustar la profundidad:

Afloje el tornillo "B" y ajuste la puerta.

Para ajustar de lado a lado:

Afloje el tornillo "C" en ambas bisagras y apriete el "B" mueve la puerta hacia afuera. Afloje el "B" y apriete el "C" mueve las puertas hacia adentro.

Página 27

Usando los soportes del estante (5), coloque un estante ajustable (F) detrás de cada área de la puerta.

Página 28

CARGA MAXIMA

Esta unidad ha sido diseñada para soportar la carga máxima anotada. El exceder estos límites puede causar inestabilidad, colapsarse y/o causar serias lesiones.

ADVERTENCIA: Riesgo de lesiones a las personas - no coloque un televisor sobre muebles. Este mueble no está aprobado para su uso con un televisor.

Página 29

Registre su producto para recibir lo siguiente:

- * Detalles de nuevas tendencias - Vistazo a lo nuevo
- * Encuestas - alec su voz entre su comunidad
- * Códigos de ofertas y descuentos exclusivos
- * Fácil y rápido servicio de partes de remplace

Para registrar su producto, visite systembuild.com

Clasificación de 5 estrellas

Visite el sitio web de su tienda local, califique su comprado y denos sus comentarios!

Nos gustaría enviar un gran "Agradecimiento" a todos nuestros clientes por tomarse el tiempo de ensamblar este producto de Systembuild, y por darnos sus valiosos comentarios.

Gracias

Couverture Avant

CE LIVRET D'INSTRUCTION CONTIENT DES INFORMATIONS **IMPORTANTES** SUR LA SÉCURITÉ. VEUILLEZ LIRE ET GARDER POUR UNE RÉFÉRENCE FUTURE

Ne retournez pas ce produit! Contactez notre équipe de service à la clientèle amicale d'abord pour obtenir de l'aide.

Appelez-nous: 1-866-452-4081 (sans frais) du Lundi au Vendredi de 9h à 17h Heure Centrale

Visitez: www.systembuild.com

ATTENTION

Le meuble peut basculer et causer des blessures graves ou la mort.

Ancrer le meuble à une planche murale dans le mur (si indiqué).

Ne laissez pas les enfants grimper sur le meuble.

Placez les articles lourds sur les étagères ou dans les tiroirs inférieurs.

Astuces Utiles (page 2)

-Ouvrez votre article dans la zone que vous prévoyez de le garder pour moins de levage lourd

-Identifier, trier et compter les pièces avant d'essayer d'assembler

-Les goujons de compression sont taraudés avec un Marteau

-Les glissières sont marquées d'un R (droit) et d'un L (gauche) pour un bon placement

-Assurez-vous toujours de faire face la pointe situé sur le haut de la Serrure de Came vers le bord extérieur

-Utiliser tous les clous fournis pour le panneau arrière et les répartir également

-Le panneau arrière doit être utilisé pour vous assurer que votre appareil est robuste

-N'utilisez pas de produits chimiques agressifs ou de nettoyeurs abrasifs sur cet appareil

-Ne jamais pousser, tirer, ou faire glisser votre meuble

Avant de Commencer (page 3)

-Lisez attentivement chaque étape et suivez le bon ordre

-Séparez et comptez toutes vos pièces et matériaux

-Donnez-vous suffisamment de place pour l'assemblage

-Avoir les outils suivants: tournevis à tête plate, #2 tournevis Phillips, et Marteau

-Attention: Si vous utilisez une perceuse électrique ou un tournevis électrique pour visser, veillez à ralentir et arrêter lorsque la vis est bien serrée. Le non-respect de cette consigne peut endommager la vis.

Système de Fixation de Came (page 3)

Ce Système de Fixation de Came sera utilisé tout au long de l'assemblage

Page 12

Dévissez les deux parties du pied. Fixez la moitié inférieure à la moitié inférieure (D) et vissez la moitié supérieure.

Page 13

Serrures à cames (1) sur la surface supérieure.

Page 16

IMPORTANT! LE PANNEAU ARRIÈRE EST UNE PARTIE STRUCTURELLE DE CET APPAREIL ET DOIT ÊTRE INSTALLÉ CORRECTEMENT.

Avec l'aide d'une autre personne, retournez votre pièce sur sa face avant comme indiqué. Positionnez le panneau arrière comme indiqué. S'aligner perpendiculairement à tous les bords extérieurs. Assurez-vous que votre unité est à angles droits. La distance d'un coin à l'autre doit être égale comme indiqué. Fixez le panneau arrière comme illustré en clouant directement dans les bords bruts.

Assurez-vous que votre unité est à angles droits. La distance d'un coin à l'autre doit être égale comme indiqué.

Alignez le bord inférieur du panneau arrière avec le bord inférieur du fond (D).

Page 18

S'assurer que la rainure dans les côtés du tiroir et centrée avec la rainure dans la façade du tiroir.

Page 19

Vous devrez taper légèrement sur les attaches d'entraînement (8) avec un marteau pour les fixer solidement.

Page 20

Remarque : Fixez d'abord les tiroirs (23c&23d), puis la poignée.

Page 21

Retournez le tiroir. A l'aide de deux vis (6), fixer le renfort du tiroir (20) comme indiqué.

Page 23

IMPORTANT : CET APPAREIL DOIT ÊTRE FIXÉ AU MUR POUR ÉVITER QU'IL NE BASCULE. SUIVEZ CES INSTRUCTIONS POUR INSTALLER LE SUPPORT DE SÉCURITÉ ANTI-BASCULEMENT FOURNI AVEC CE PRODUIT.

OPTION 1 : Fixation dans un poteau mural (méthode préférée)

À l'aide d'un détecteur de montants, repérez un montant dans le mur. Placez votre appareil contre le mur, le support de sécurité étant aligné à cet endroit. Pour faciliter l'enfoncement de la vis, vous pouvez percer un trou pilote de 1/8" de diamètre (3mm) à travers le support de sécurité dans le montant. Enfoncez la vis à travers le support de sécurité dans le montant mural. Serrez la vis qui n'a pas été serrée à fond à l'étape 3.

OPTION 2 : Fixation dans la cloison sèche

Placez votre appareil à l'endroit désiré contre un mur et marquez le mur à travers le support de sécurité, puis déplacez votre appareil sur le côté. Percez un trou de 3/16" de diamètre (5mm) dans le panneau mural. Tapotez l'ancrage mural dans le trou jusqu'à ce qu'il soit à ras. Mettez votre appareil en place et fixez le support mural à l'ancrage mural à l'aide de la vis. Serrez la vis qui n'a pas été serrée à fond à l'étape 3.

Pour la maçonnerie, le béton ou d'autres matériaux muraux :

Consultez votre quincaillerie locale pour connaître les ancrages appropriés pour fixer solidement le support de sécurité.

Page 24

Avec l'aide d'une autre personne, attachez les quatre portes comme indiqué en visser les vis de la plaque de charnière dans les panneaux latéraux.

Peler et coller des pare-chocs (16) sur le bord avant de l'étagère supérieure où les portes supérieures (G) se rencontrent.

Page 25

Installez le tiroir comme indiqué ci-dessous. Suivez les détails d'ajustement ci-dessous pour ajuster le tiroir.

Remarque : Les trous de support de tiroir sont insérés. L'avant du tiroir peut être ajusté en desserrant les vis, en faisant les ajustements nécessaires et en resserrant les vis.

Page 26

Pour ajuster la hauteur verticale :

Desserrez les vis "A" sur les deux charnières. Ils sont généralement dans des trous à fentes qui vous permet de s'ajuster vers le haut ou le bas de quelques mm. Puis resserrez-vous.

Pour ajuster la profondeur :

Desserrez la vis "B" et ajustez la porte.

Pour s'adapter d'un côté à l'autre :

Desserrez la vis "C" sur les DEUX charnières et serrez "B" ajuste la porte vers l'extérieur. Desserrer "B" et serrez "C" ajuste les portes vers l'intérieur.

Page 27

A l'aide des supports de tablettes (5), placer une tablette réglable (F) derrière chaque zone de porte.

Page 28

CHARGES MAXIMALES

Ce meuble a été conçu pour supporter les charges maximales indiquées. En excédant ces limites de charge, le meuble pourrait devenir instable, s'effondrer, et/ou causer des blessures graves.

AVERTISSEMENT : Risque de blessure corporelle - ne pas placer une télévision sur ce meuble. Ce meuble n'est pas approuvé pour une utilisation avec une télévision.

Page 29

Enregistrez votre produit pour recevoir les éléments suivantes:

- * Détails sur les nouvelles tendances - un aperçu sur les nouveautés
- * Sondages - avoir une voix au sein de notre communauté
- * Offres exclusives et codes promo
- * Service de pièces de rechange rapide et facile

Pour enregistrer votre produit, visitez systembuild.com

5 Étoiles

Visitez le site Web de votre détaillant local, évaluez votre produit acheté et laissez-nous quelques commentaires !

Nous tenons à offrir un grand "Merci" à tous nos clients pour avoir pris le temps d'assembler ce produit "Systembuild", et de nous donner vos commentaires précieux.

Merci